

EE415: Game Theory

Game Theory (Static Game with Incomplete Information)

Asst. Prof. Dr. Pornthep Benyaapikul

Faculty of Economics, Thammasat University

March 2018

Games of Incomplete Information: Bayesian Games

- In the games we have studied so far (both simultaneous-move and extensive form games), each player knows the characteristics of the other players that are relevant to their decision making, in particular, their preferences/payoff functions. Games of complete information.
- Now we study **games of incomplete information (Bayesian games)**, in which at least some players are not completely informed of some other players' preferences, or some other characteristics of the other players that are relevant to their decision making (such as their information or beliefs).

Example 1: variant of BoS with one-sided incomplete information

- Player 2 knows if she wishes to meet player 1, but player 1 is not sure if player 2 wishes to meet her. Player 1 thinks each case has a $1/2$ probability.

Prob. 1/2		1	Prob. 1/2	
2	B		S	
B	2, 1		0, 0	
S	0, 0		1, 2	
2 wishes to meet 1				
	B		S	2
	2, 0		0, 2	
	0, 1		1, 0	
2 wishes to avoid 1				

- We say player 2 has two **types**, or there are two **states of the world** (in one state player 2 wishes to meet 1, in the other state player 2 does not).

Example 1: solution

	Prob. 1/2		1	Prob. 1/2	
2	B	S		B	S
B	2, 1	0, 0		B	2, 0
S	0, 0	1, 2		S	0, 1
	2 wishes to meet 1			2 wishes to avoid 1	

- This is a Bayesian simultaneous-move game, so we look for the **Bayesian Nash equilibria**. In a Bayesian NE,
 - ▷ the action of player 1 is optimal, given the actions of the two types of player 2 *and* player 1's belief about the state of the world;
 - ▷ the action of each type of player 2 is optimal, given the action of player 1.
- The unique pure-strategy equilibrium is $[B, (B, S)]$, in which the first component is player 1's action, and the second component (in parenthesis) is the pair of actions of the two types of player 2.

Example 2: variant of BoS with two-sided incomplete information

- Now neither player is sure if the other player wishes to meet.

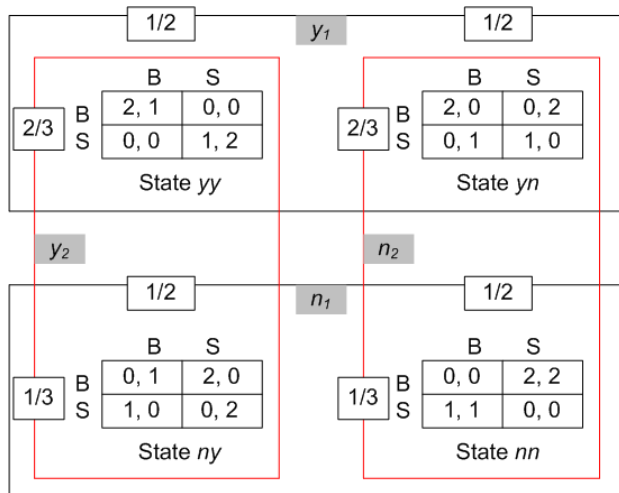

- Player 1's types: y_1 and n_1 ; player 2's types: y_2 and n_2 .

Example 2: $[(B,B), (B,S)]$ as NE

- $[(B, B), (B, S)]$ is a pure-strategy NE of the game.

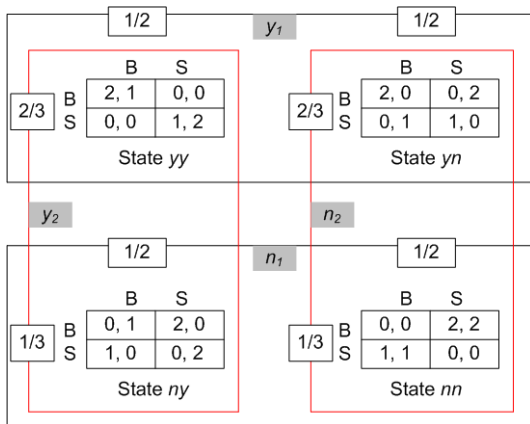

- If player 1 always plays B , certainly player 2 will play B if her type is y_2 and play S if n_2 . So player 2's (B, S) is indeed best response to player 1's (B, B) .

Example 2: [(B,B), (B,S)] as NE (cont.)

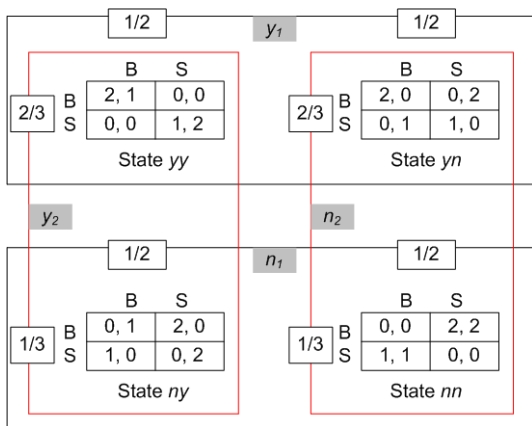

- Player 1's (B, B) is also best response to player 2's (B, S) .
 - ▷ For type y_1 ,

$$u_1(B|(B, S)) = \frac{1}{2} \cdot 2 + \frac{1}{2} \cdot 0 > u_1(S|(B, S)) = \frac{1}{2} \cdot 0 + \frac{1}{2} \cdot 1.$$
 - ▷ For type n_1 ,

$$u_1(B|(B, S)) = \frac{1}{2} \cdot 0 + \frac{1}{2} \cdot 2 > u_1(S|(B, S)) = \frac{1}{2} \cdot 1 + \frac{1}{2} \cdot 0.$$

Example 2: $[(B,B), (B,S)]$ as NE (cont.)

- Therefore $[(B, B), (B, S)]$ is a pure-strategy NE.

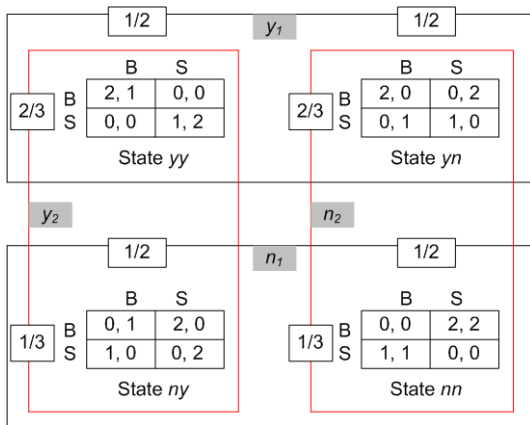

- Is $[(S, B), (S, S)]$ a pure-strategy NE of the game?

Example 2: $[(S,B), (S,S)]$ as NE

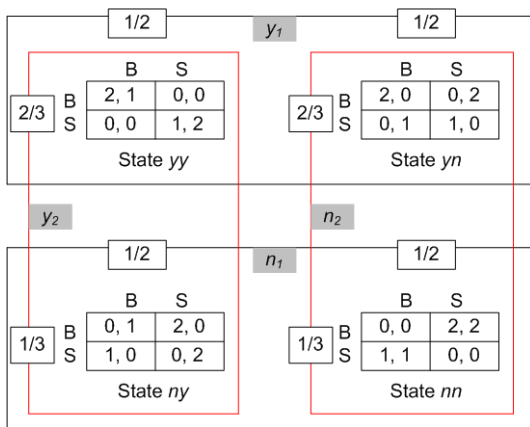

- If player 2 always plays S , player 1's best response is indeed S if her type is y_1 and B if n_1 . So player 1's (S, B) is best response to player 2's (S, S) .

Example 2: NE [(S,B), (S,S)] (cont.)

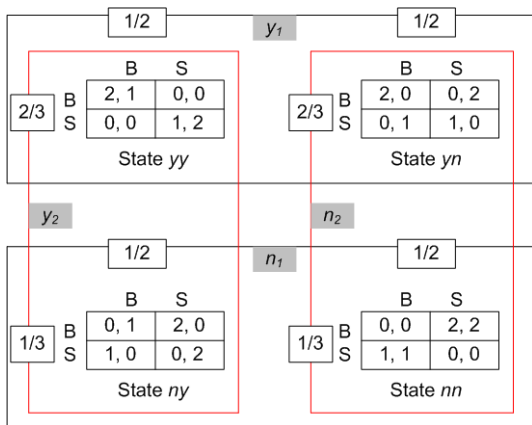

- Player 2's (S, S) is also best response to player 1's (S, B).
 - ▷ For type y_2 ,

$$u_2(S|(S, B)) = \frac{2}{3} \cdot 2 + \frac{1}{3} \cdot 0 > u_2(B|(S, B)) = \frac{2}{3} \cdot 0 + \frac{1}{3} \cdot 1.$$
 - ▷ For type n_2 ,

$$u_2(S|(S, B)) = \frac{2}{3} \cdot 0 + \frac{1}{3} \cdot 2 = u_2(B|(S, B)) = \frac{2}{3} \cdot 1 + \frac{1}{3} \cdot 0.$$

Summary

- A **state** is a complete description of one collection of the players' relevant characteristics, including their preferences and their information.
- The **type** of a player embodies any private information that is relevant to the player's decision making, including a player's payoff function, her beliefs about other player's pay-off functions, her beliefs about other players' beliefs about her beliefs, and so on.
- In a Bayesian game, each type of each player chooses an action.
- In BNE, the action chosen by each type of each player is optimal given her belief about the state of the world and the actions chosen by every type of every other player.

More information may hurt (1)

- In single-person decision problems, a person cannot be worse off with more information. In strategic interactions, a player may be worse off if she has more information and other players know that she has more information.
- In the following game, each player believes that both states are equally likely. $0 < \epsilon < 1/2$.

		$1/2$			1	$1/2$			
		$1/2$			2	$1/2$			
		L	M	R			L	M	R
T	1, 2ϵ	1, 0	1, 3ϵ			T	1, 2ϵ	1, 3ϵ	1, 0
B	2, 2	0, 0	0, 3			B	2, 2	0, 3	0, 0
		State ω_1					State ω_2		

- What is the NE?

More information may hurt (2)

- Player 2's unique best response to each action of player 1 is L . Player 1's unique best response to L is B . So the unique NE is (B, L) , with each player getting a payoff of 2.

		$1/2$			1	$1/2$			
		$1/2$			2	$1/2$			
		L	M	R			L	M	R
T	1, 2ϵ	1, 0	1, 3ϵ			T	1, 2ϵ	1, 3ϵ	1, 0
B	2, 2	0, 0	0, 3			B	2, 2	0, 3	0, 0
		State ω_1					State ω_2		

- What if player 2 knows the state for sure?

More information may hurt (3)

		$1/2$			1			$1/2$											
		2						2											
		L			M			R			L			M			R		
T	1, 2ϵ	1, 0	1, 3ϵ	1, 2ϵ	1, 3ϵ	1, 0	2, 2	0, 3	0, 0	2, 2	0, 3	0, 0							
B	2, 2	0, 0	0, 3																
		State ω_1						State ω_2											

- Player 2 has a dominant strategy of R in state ω_1 , and a dominant strategy of M in state ω_2 . When player 2 is only going to play R or M , player 1 has a dominant strategy of T . So the unique NE is now $[T, (R, M)]$.
- Regardless of the state, player 2's payoff is now $3\epsilon < 2$, since $\epsilon < 1/2$.

Uncertainty about players' knowledge: information contagion (1)

- Bayesian games can not only model uncertainty about players' preferences, but also uncertainty about each other's *knowledge*.
- In the following, player 1 (she) can distinguish state α from other states, but cannot distinguish state β from state γ ; player 2 (he) can distinguish state γ from other state, but cannot distinguish state α from state β .

The diagram illustrates a signaling game with three states: α , β , and γ . Player 1 moves first, choosing between L and R. Player 2 then moves, choosing between L and R. Payoffs are given as (Player 1, Player 2).

1	3/4		2	1/4		2		
	L	R		L	R			
L	2, 2	0, 0	L	2, 2	0, 0	L	2, 2	0, 0
R	3, 0	1, 1	R	0, 0	1, 1	R	0, 0	1, 1
State α			State β			State γ		

Information contagion (2)

- Note that player 2's preferences are the same in all three states, and player 1's preferences are the same in states β and γ .

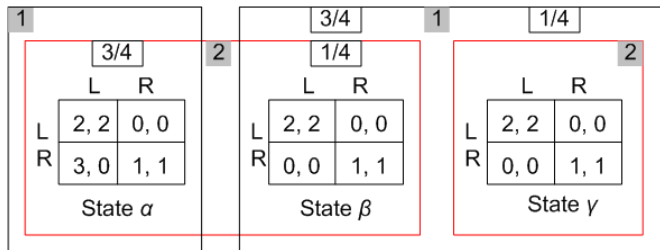

- Therefore, in state γ , each player knows the other player's preferences, and player 2 knows that player 1 knows his preferences. But player 1 does not know that player 2 knows her preferences (player 1 thinks it might be state β , in which case player 2 does not know if it is state β or α).

Information contagion (3)

- If both players are completely informed in state γ , both (L, L) and (R, R) are NE.

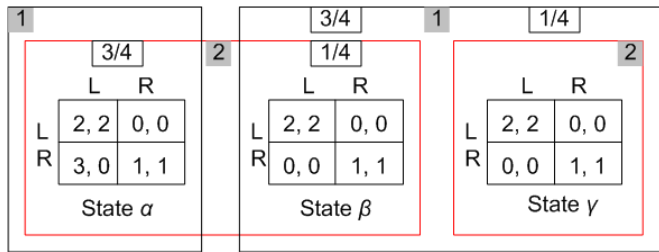

- But this whole Bayesian game has a unique NE. What is it?
 - ▷ First consider player 1's choice in state α . (R is dominant.)
 - ▷ Next consider player 2's choice when he knows the state is either α or β . (R is better than L given 1's choice in α .)
 - ▷ Then consider player 1's choice when she knows the state is either β or γ . (R is better, given R 1 and 2's actions in α and β .)
 - ▷ Finally consider player 2's choice in state γ . (R is better.)

Information contagion (4)

- Information contagion leads to the unique NE: (R, R) .
- Consider the following extension:

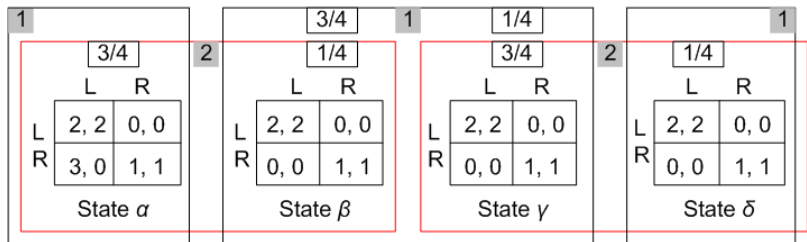

- In state δ , player 2 knows player 1's preferences, but player 2 does not know if player 1 knows that player 2 knows player 1's preferences (player 2 does not know if the state is γ or δ ; if γ , player 1 knows it can be β ; if β , player 2 would think it might be α , in which case player 1's preferences are different.)
- (R, R) , however, is still the unique NE.

“They don't know that we know they know we know...”

- The Rubinstein email game
- The eye colors puzzle
- Friends: http://www.youtube.com/watch?v=Fp14D3_b6DU

Some basic facts about probability

- Let E and F be two events, each occurring respectively with probability $Pr(E)$ and $Pr(F)$. We have the following facts.
- The probability that event E occurs, given that F has occurred, is $Pr(E|F) = \frac{Pr(E,F)}{Pr(F)}$, where $Pr(\cdot|\cdot)$ indicates the *conditional probability*, and $Pr(E, F)$ is the probability that both events occur.
- In other words,
$$Pr(E, F) = Pr(F)Pr(E|F) = Pr(F, E) = Pr(E)Pr(F|E).$$
- Further, denote the event that E does not occur as E^c (c means complement), then $Pr(F) = Pr(E, F) + Pr(E^c, F) = Pr(E)Pr(F|E) + Pr(E^c)Pr(F|E^c)$.
- Then, $Pr(E|F) = \frac{Pr(E)Pr(F|E)}{Pr(E)Pr(F|E) + Pr(E^c)Pr(F|E^c)}$.

Bayes' rule

- More generally, let E_1, E_2, \dots, E_n be a collection of exclusive events (meaning exactly one of these events must occur).
- Then the probability of a particular event E_k conditional on event F is

$$Pr(E_k|F) = \frac{Pr(F|E_k)Pr(E_k)}{\sum_{j=1}^n Pr(F|E_j)Pr(E_j)}.$$

- This is an extremely important formula, called **Bayes' rule**, which enables us to calculate the posterior probability about an event based on the prior probability and new information/evidence.
- **Prior belief**: a player's initial belief about the probability of an event (i.e., $Pr(E_k)$).
- **Posterior belief**: a player's updated belief after receiving new information/evidence (i.e., $Pr(E_k|F)$).

A model of juries: setup (1)

- A number of jurors need to decide to convict or acquit a defendant. *A unanimous verdict is required for conviction.*
- Each juror comes to the trial with a prior belief that the defendant is guilty with probability π . Then they receive a piece of information. But each may interpret the information differently.
- If a juror interprets the information as evidence of guilt, we say she receives a signal g (or, the juror's type is g); if a juror interprets the information as evidence of innocence, we say she receives a signal c (or, the juror's type is c , with c standing for clean).
- Denote the event that the defendant is actually guilty as G ; denote the event that the defendant is actually innocent (clean) as C .

A model of juries: setup (2)

- When G occurs (the defendant is actually guilty), the probability that a given juror receives the signal g is p , $p > 1/2$; in other words, $Pr(g|G) = p > 1/2$.
- When C occurs, the probability that a given juror receives the signal c is q , $q > 1/2$; in other words, $Pr(c|C) = q > 1/2$.
- Each juror's payoffs

$$= \begin{cases} 0, & \text{if guilty defendant convicted or} \\ & \text{innocent defendant acquitted;} \\ -z, & \text{if innocent defendant convicted;} \\ -(1-z), & \text{if guilty defendant acquitted.} \end{cases} \quad (1)$$

- z is cost of convicting an innocent defendant (type I error), and $1 - z$ is the cost of acquitting a guilty defendant (type II error).

One juror

- First consider the case in which there is only one juror.
- Suppose the juror receives the signal c (she interprets the information as evidence of innocence), the probability she thinks the defendant is actually guilty is

$$\begin{aligned} P(G|c) &= \frac{Pr(c|G)Pr(G)}{Pr(c|G)Pr(G) + Pr(c|C)Pr(C)} \\ &= \frac{(1-p)\pi}{(1-p)\pi + q(1-\pi)}. \end{aligned}$$

- By (1), the juror will acquit the defendant if $(1-z)P(G|c) \leq z(1-P(G|c))$, or

$$z \geq P(G|c) = \frac{(1-p)\pi}{(1-p)\pi + q(1-\pi)}.$$

One juror (cont.)

- Suppose the juror receives the signal g , a similar calculation yields that she will convict the defendant if

$$z \leq \frac{p\pi}{p\pi + (1-q)(1-\pi)}.$$

- Therefore the juror optimally acts according to her interpretation of the information if

$$\frac{(1-p)\pi}{(1-p)\pi + q(1-\pi)} \leq z \leq \frac{p\pi}{p\pi + (1-q)(1-\pi)}.$$

Two jurors

- Now suppose there are two jurors. Is there an equilibrium in which each juror votes according to her signal?
- Suppose juror 2 votes according to her signal: vote to acquit if her signal is c and vote to convict if her signal is g .
- If juror 2's signal is c , then juror 1's vote does not matter for the outcome (unanimity is required for conviction).
- So juror 1 can ignore the possibility that juror 2's signal may be c , and assume it is g .
- We want to see when juror 1 will vote to acquit when her signal is c . When juror 1's signal is c and juror 2's signal is g , juror 1 thinks the probability that the defendant is guilty is

$$\begin{aligned} P(G|c, g) &= \frac{Pr(c, g|G)Pr(G)}{Pr(c, g|G)Pr(G) + Pr(c, g|C)Pr(C)} \\ &= \frac{(1-p)p\pi}{(1-p)p\pi + q(1-q)(1-\pi)}. \end{aligned}$$

Two jurors (cont.)

- By (1), juror 1 will vote to acquit the defendant if $(1 - z)P(G|c, g) \leq z(1 - P(G|c, g))$, or

$$z \geq P(G|c, g) = \frac{(1 - p)p\pi}{(1 - p)p\pi + q(1 - q)(1 - \pi)}.$$

- By a similar calculation, if juror 1 receives a signal g , she will vote to convict if

$$z < \frac{p^2\pi}{p^2\pi + (1 - q)^2(1 - \pi)}.$$

- Therefore juror 1 optimally votes according to her interpretation of the information

$$\frac{(1 - p)p\pi}{(1 - p)p\pi + q(1 - q)(1 - \pi)} \leq z \leq \frac{p^2\pi}{p^2\pi + (1 - q)^2(1 - \pi)}.$$

One juror vs. two jurors

- To recap, when there is only one juror, she acts according to her signal if

$$\frac{(1-p)\pi}{(1-p)\pi + q(1-\pi)} \leq z \leq \frac{p\pi}{p\pi + (1-q)(1-\pi)}. \quad (2)$$

- When there are two jurors, they vote according to their signals if

$$\frac{(1-p)p\pi}{(1-p)p\pi + q(1-q)(1-\pi)} \leq z \leq \frac{p^2\pi}{p^2\pi + (1-q)^2(1-\pi)}. \quad (3)$$

- Compare the left sides of (2) and (3), and recall that $p > 1/2 > 1 - q$.
- The lowest value of z with which jurors vote according to their signals is higher in the two-juror case than in the one-juror case. **A juror is less worried about convicting an innocent person when there are two jurors.**

Many jurors (1)

- Now suppose the number of jurors is n . Is there an equilibrium in which each juror votes according to her signal?
- Suppose every juror other than juror 1 votes according to her signal: vote to acquit if her signal is c and vote to convict if her signal is g .
- Again juror 1 can ignore the possibility that some other jurors' signals may be c , and assume every other juror's signal is g .
- And again we want to see when juror 1 will vote to acquit when her signal is c . When juror 1's signal c and every other juror's signal is g , juror 1 thinks the probability that the defendant is guilty is

$$\begin{aligned}
 P(G|c, g, \dots, g) &= \frac{Pr(c, g, \dots, g|G)Pr(G)}{Pr(c, g, \dots, g|G)Pr(G) + Pr(c, g, \dots, g|C)Pr(C)} \\
 &= \frac{(1-p)p^{n-1}\pi}{(1-p)p^{n-1}\pi + q(1-q)^{n-1}(1-\pi)}.
 \end{aligned}$$

Many jurors (2)

- By (1), juror 1 will vote for acquittal if $(1 - z)P(G|c, g, \dots, g) \leq z(1 - P(G|c, g, \dots, g))$, or

$$z \geq \frac{(1 - p)p^{n-1}\pi}{(1 - p)p^{n-1}\pi + q(1 - q)^{n-1}(1 - \pi)}$$

$$= \frac{1}{1 + \frac{q}{1-p} \left(\frac{1-q}{p}\right)^{n-1} \left(\frac{1-\pi}{\pi}\right)}.$$

- Given that $p > 1 - q$, the denominator approaches 1 as n increases. So the lower bound on z for which juror 1 votes for acquittal when her signal is c approaches 1 as n increases. In other words, *in a large jury, if jurors care even slightly about acquitting a guilty defendant (type II error), then a juror who interprets a piece of information as evidence of innocence will nevertheless vote for conviction.*

Many jurors: equilibria

- Therefore, in a large jury in which the jurors are concerned about acquitting a guilty defendant, there is no Nash equilibrium in which every juror votes according to her signal.
- Is there a NE in which every juror votes for acquittal regardless of her signal (easy), and is there a NE in which every juror votes for conviction regardless of her signal (slightly harder)?
- There is also a mixed strategy NE for some values of z , in which a juror votes for conviction if her signal is g , and randomizes between acquittal and conviction if her signal is c . Interestingly, in this NE the probability an innocent defendant is convicted increases as n increases.