

Data Mining: Data

Lecture Notes
Introduction to Data Mining

Outline

- Attributes and Objects
- Types of Data
- Data Quality
- Similarity and Distance
- Data Preprocessing

What is Data?

- Collection of *data objects* and their *attributes*
- An *attribute* is a property or characteristic of an object
 - Examples: eye color of a person, temperature, etc.
 - Attribute is also known as variable, field, characteristic, dimension, or feature
- A collection of attributes describe an *object*
 - Object is also known as record, point, case, sample, entity, or instance

Attributes

<i>Tid</i>	Refund	Marital Status	Taxable Income	Cheat
1	Yes	Single	125K	No
2	No	Married	100K	No
3	No	Single	70K	No
4	Yes	Married	120K	No
5	No	Divorced	95K	Yes
6	No	Married	60K	No
7	Yes	Divorced	220K	No
8	No	Single	85K	Yes
9	No	Married	75K	No
10	No	Single	90K	Yes

Attribute Values

- **Attribute values** are numbers or symbols assigned to an attribute for a particular object
- Distinction between attributes and attribute values
 - Same attribute can be mapped to different attribute values
 - ◆ Example: height can be measured in feet or meters
 - Different attributes can be mapped to the same set of values
 - ◆ Example: Attribute values for ID and age are integers
 - But properties of attribute can be different than the properties of the values used to represent the attribute

Measurement of Length

- The way you measure an attribute may not match the attributes properties.

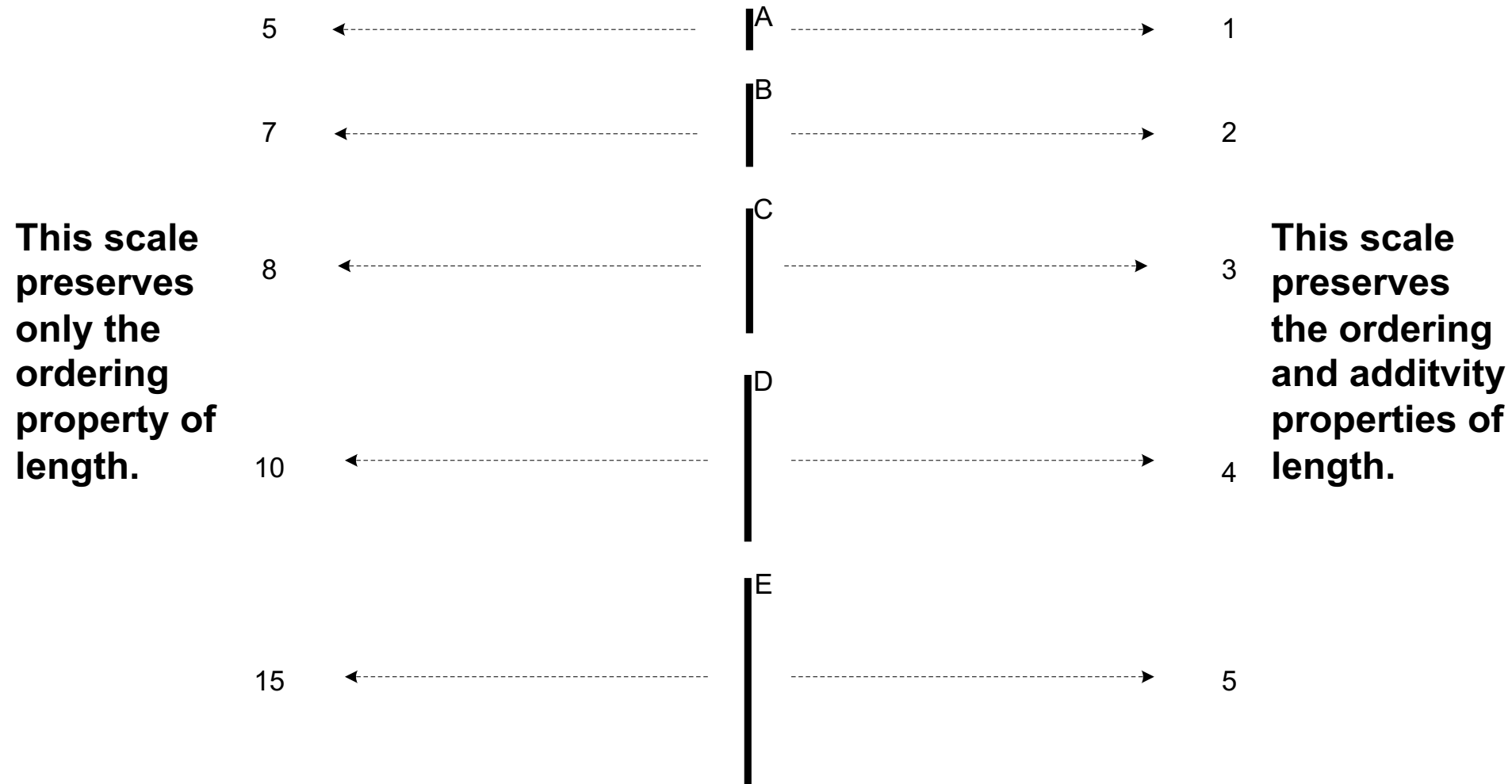

Types of Attributes

- There are different types of attributes
 - **Nominal**
 - ◆ Examples: ID numbers, eye color, zip codes
 - **Ordinal**
 - ◆ Examples: rankings (e.g., taste of potato chips on a scale from 1-10), grades, height {tall, medium, short}
 - **Interval**
 - ◆ Examples: calendar dates, temperatures in Celsius or Fahrenheit.
 - **Ratio**
 - ◆ Examples: temperature in Kelvin, length, counts, elapsed time (e.g., time to run a race)

Properties of Attribute Values

- The type of an attribute depends on which of the following properties/operations it possesses:
 - Distinctness: $= \neq$
 - Order: $< >$
 - Differences are meaningful : $+ -$
 - Ratios are meaningful $* /$
 - Nominal attribute: distinctness
 - Ordinal attribute: distinctness & order
 - Interval attribute: distinctness, order & meaningful differences
 - Ratio attribute: all 4 properties/operations

Difference Between Ratio and Interval

- Is it physically meaningful to say that a temperature of 10° is twice that of 5° on
 - the Celsius scale?
 - the Fahrenheit scale?
 - the Kelvin scale?

- Consider measuring the height above average
 - If Bill's height is three inches above average and Bob's height is six inches above average, then would we say that Bob is twice as tall as Bill?
 - Is this situation analogous to that of temperature?

		Attribute Type	Description	Examples	Operations
Categorical	Qualitative	Nominal	Nominal attribute values only distinguish. (=, ≠)	zip codes, employee ID numbers, eye color, sex: { <i>male</i> , <i>female</i> }	mode, entropy, contingency correlation, χ^2 test
		Ordinal	Ordinal attribute values also order objects. (<, >)	hardness of minerals, { <i>good</i> , <i>better</i> , <i>best</i> }, grades, street numbers	median, percentiles, rank correlation, run tests, sign tests
Numeric	Quantitative	Interval	For interval attributes, differences between values are meaningful. (+, -)	calendar dates, temperature in Celsius or Fahrenheit	mean, standard deviation, Pearson's correlation, <i>t</i> and <i>F</i> tests
		Ratio	For ratio variables, both differences and ratios are meaningful. (*, /)	temperature in Kelvin, monetary quantities, counts, age, mass, length, current	geometric mean, harmonic mean, percent variation

This categorization of attributes is due to S. S. Stevens

		Attribute Type	Transformation	Comments
Categorical Qualitative		Nominal	Any permutation of values	If all employee ID numbers were reassigned, would it make any difference?
		Ordinal	An order preserving change of values, i.e., $new_value = f(old_value)$ where f is a monotonic function	An attribute encompassing the notion of good, better best can be represented equally well by the values {1, 2, 3} or by {0.5, 1, 10}.
Numeric Quantitative		Interval	$new_value = a * old_value + b$ where a and b are constants	Thus, the Fahrenheit and Celsius temperature scales differ in terms of where their zero value is and the size of a unit (degree).
		Ratio	$new_value = a * old_value$	Length can be measured in meters or feet.

This categorization of attributes is due to S. S. Stevens

Discrete and Continuous Attributes

● Discrete Attribute

- Has only a finite or countably infinite set of values
- Examples: zip codes, counts, or the set of words in a collection of documents
- Often represented as integer variables.
- Note: **binary attributes** are a special case of discrete attributes

● Continuous Attribute

- Has real numbers as attribute values
- Examples: temperature, height, or weight.
- Practically, real values can only be measured and represented using a finite number of digits.
- Continuous attributes are typically represented as floating-point variables.

Asymmetric Attributes

- Only presence (a non-zero attribute value) is regarded as important
 - ◆ Words present in documents
 - ◆ Items present in customer transactions
- If we met a friend in the grocery store would we ever say the following?

“I see our purchases are very similar since we didn’t buy most of the same things.”

Critiques of the attribute categorization

- Incomplete

- Asymmetric binary
- Cyclical
- Multivariate
- Partially ordered
- Partial membership
- Relationships between the data

- Real data is approximate and noisy

- This can complicate recognition of the proper attribute type
- Treating one attribute type as another may be approximately correct

Key Messages for Attribute Types

- The types of operations you choose should be “meaningful” for the type of data you have
 - Distinctness, order, meaningful intervals, and meaningful ratios are only four (among many possible) properties of data
 - The data type you see – often numbers or strings – may not capture all the properties or may suggest properties that are not present
 - Analysis may depend on these other properties of the data
 - ◆ Many statistical analyses depend only on the distribution
 - In the end, what is meaningful can be specific to domain

Important Characteristics of Data

- Dimensionality (number of attributes)
 - ◆ High dimensional data brings a number of challenges
- Sparsity
 - ◆ Only presence counts
- Resolution
 - ◆ Patterns depend on the scale
- Size
 - ◆ Type of analysis may depend on size of data

Types of data sets

- Record
 - Data Matrix
 - Document Data
 - Transaction Data
- Graph
 - World Wide Web
 - Molecular Structures
- Ordered
 - Spatial Data
 - Temporal Data
 - Sequential Data
 - Genetic Sequence Data

Record Data

- Data that consists of a collection of records, each of which consists of a fixed set of attributes

<i>Tid</i>	Refund	Marital Status	Taxable Income	Cheat
1	Yes	Single	125K	No
2	No	Married	100K	No
3	No	Single	70K	No
4	Yes	Married	120K	No
5	No	Divorced	95K	Yes
6	No	Married	60K	No
7	Yes	Divorced	220K	No
8	No	Single	85K	Yes
9	No	Married	75K	No
10	No	Single	90K	Yes

Data Matrix

- If data objects have the same fixed set of numeric attributes, then the data objects can be thought of as points in a multi-dimensional space, where each dimension represents a distinct attribute
- Such a data set can be represented by an m by n matrix, where there are m rows, one for each object, and n columns, one for each attribute

Projection of x Load	Projection of y load	Distance	Load	Thickness
10.23	5.27	15.22	2.7	1.2
12.65	6.25	16.22	2.2	1.1

Document Data

- Each document becomes a 'term' vector
 - Each term is a component (attribute) of the vector
 - The value of each component is the number of times the corresponding term occurs in the document.

	team	coach	play	ball	score	game	win	lost	timeout	season
Document 1	3	0	5	0	2	6	0	2	0	2
Document 2	0	7	0	2	1	0	0	3	0	0
Document 3	0	1	0	0	1	2	2	0	3	0

Transaction Data

- A special type of data, where
 - Each transaction involves a set of items.
 - For example, consider a grocery store. The set of products purchased by a customer during one shopping trip constitute a transaction, while the individual products that were purchased are the items.
 - Can represent transaction data as record data

<i>TID</i>	<i>Items</i>
1	Bread, Coke, Milk
2	Beer, Bread
3	Beer, Coke, Diaper, Milk
4	Beer, Bread, Diaper, Milk
5	Coke, Diaper, Milk

Graph Data

- Examples: Generic graph, a molecule, and webpages

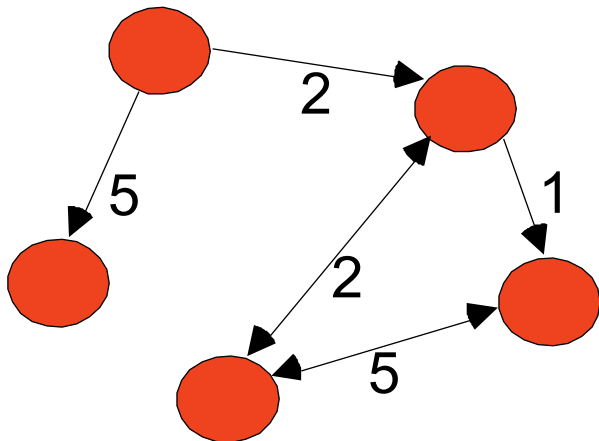

Useful Links:

- [Bibliography](#)
- Other Useful Web sites
 - [ACM SIGKDD](#)
 - [KDnuggets](#)
 - [The Data Mine](#)

Knowledge Discovery and Data Mining Bibliography

(Gets updated frequently, so visit often!)

- [Books](#)
- [General Data Mining](#)

Book References in Data Mining and Knowledge Discovery

Usama Fayyad, Gregory Piatetsky-Shapiro, Padhraic Smyth, and Ramasamy uthurasamy, "Advances in Knowledge Discovery and Data Mining", AAAI Press/the MIT Press, 1996.

J. Ross Quinlan, "C4.5: Programs for Machine Learning", Morgan Kaufmann Publishers, 1993.
Michael Berry and Gordon Linoff, "Data Mining Techniques (For Marketing, Sales, and Customer Support)", John Wiley & Sons, 1997.

General Data Mining

Usama Fayyad, "Mining Databases: Towards Algorithms for Knowledge Discovery", Bulletin of the IEEE Computer Society Technical Committee on data Engineering, vol. 21, no. 1, March 1998.

Christopher Matheus, Philip Chan, and Gregory Piatetsky-Shapiro, "Systems for knowledge Discovery in databases", IEEE Transactions on Knowledge and Data Engineering, 5(6):903-913, December 1993.

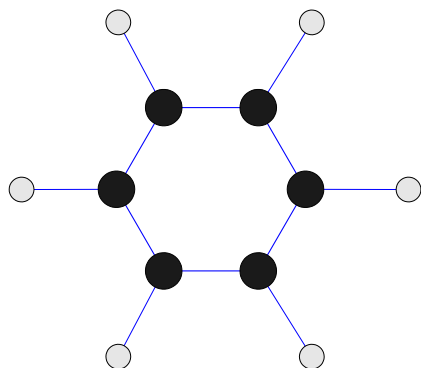

Benzene Molecule: C6H6

Ordered Data

- Sequences of transactions

Items/Events

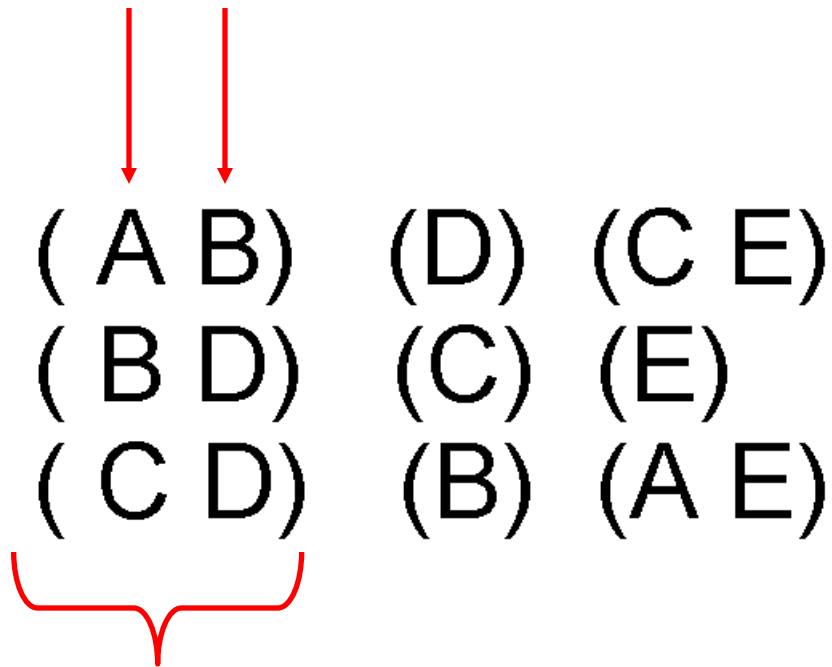

**An element of
the sequence**

Ordered Data

- Genomic sequence data

**GGTTCCGCCTTCAGCCCCGCGCC
CGCAGGGCCCGCCCCGCGCCGTC
GAGAAGGGCCCGCCTGGCGGGCG
GGGGGAGGCGGGGCCGCCCGAGC
CCAACCGAGTCCGACCAGGTGCC
CCCTCTGCTCGGCCTAGACCTGA
GCTCATTAGGCGGCAGCGGACAG
GCCAAGTAGAACACGCGAAGCGC
TGGGCTGCCTGCTGCGACCAGGG**

Ordered Data

- Spatio-Temporal Data

**Average Monthly
Temperature of
land and ocean**

Jan

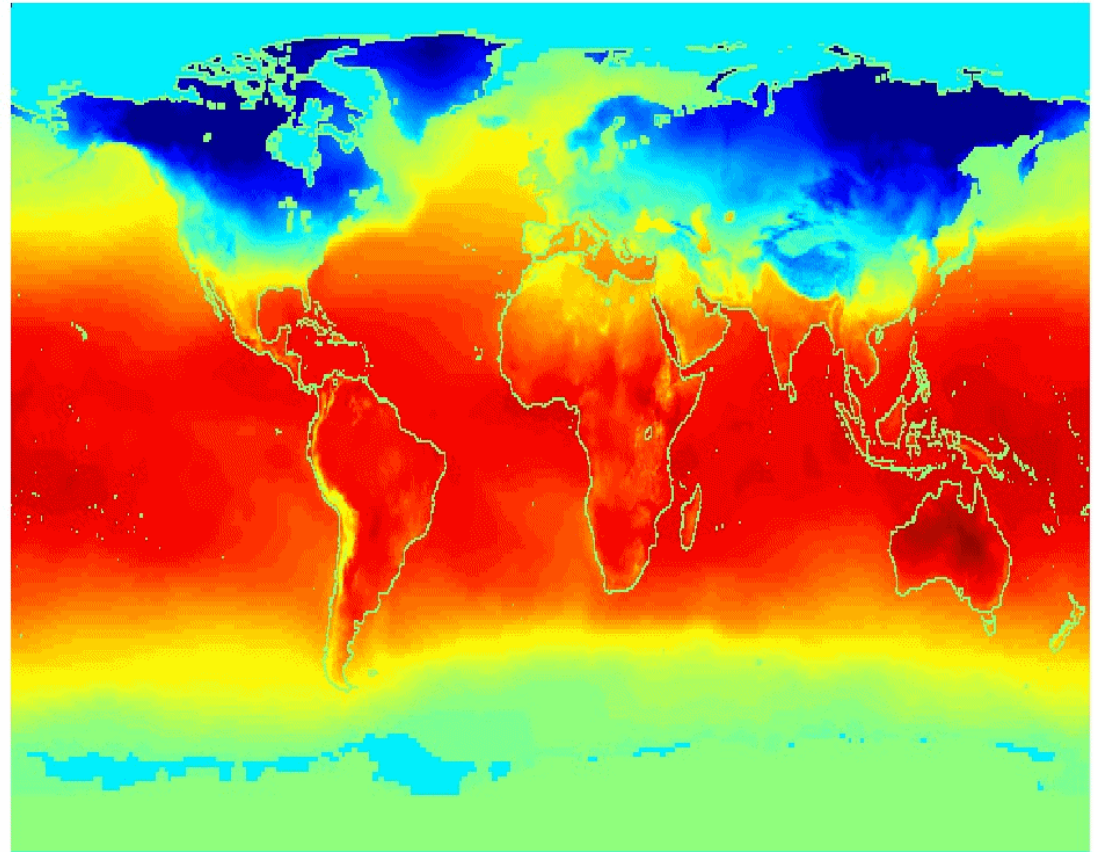

Data Quality

- Poor data quality negatively affects many data processing efforts
- Data mining example: a classification model for detecting people who are loan risks is built using poor data
 - Some credit-worthy candidates are denied loans
 - More loans are given to individuals that default

Data Quality ...

- What kinds of data quality problems?
- How can we detect problems with the data?
- What can we do about these problems?

- Examples of data quality problems:
 - Noise and outliers
 - Wrong data
 - Fake data
 - Missing values
 - Duplicate data

Noise

- For objects, noise is an extraneous object
- For attributes, noise refers to modification of original values
 - Examples: distortion of a person's voice when talking on a poor phone and "snow" on television screen
 - The figures below show two sine waves of the same magnitude and different frequencies, the waves combined, and the two sine waves with random noise
 - ◆ The magnitude and shape of the original signal is distorted

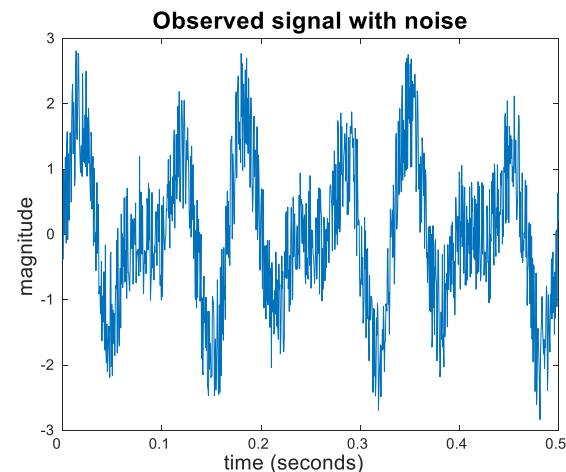
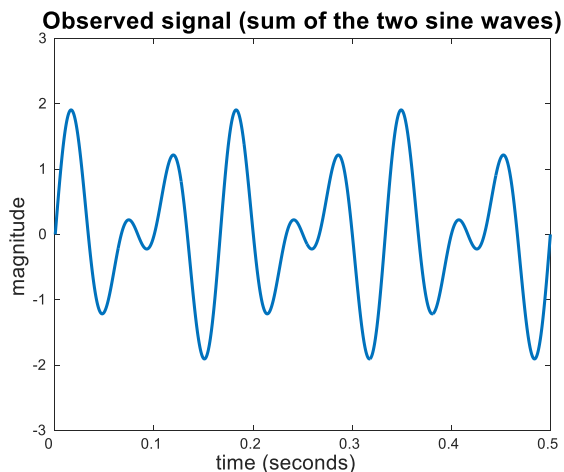
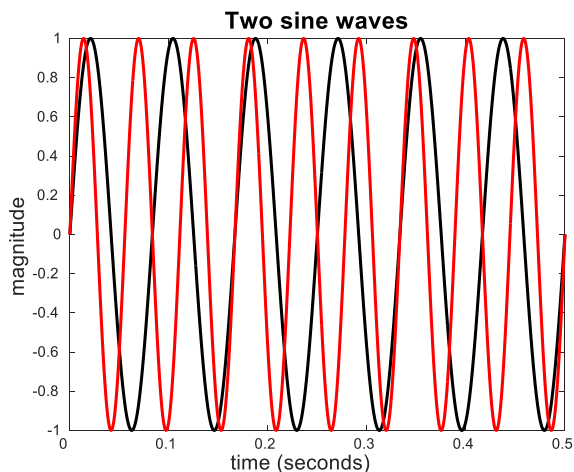

Outliers

- **Outliers** are data objects with characteristics that are considerably different than most of the other data objects in the data set

- **Case 1:** Outliers are noise that interferes with data analysis
- **Case 2:** Outliers are the goal of our analysis
 - ◆ Credit card fraud
 - ◆ Intrusion detection

- Causes?

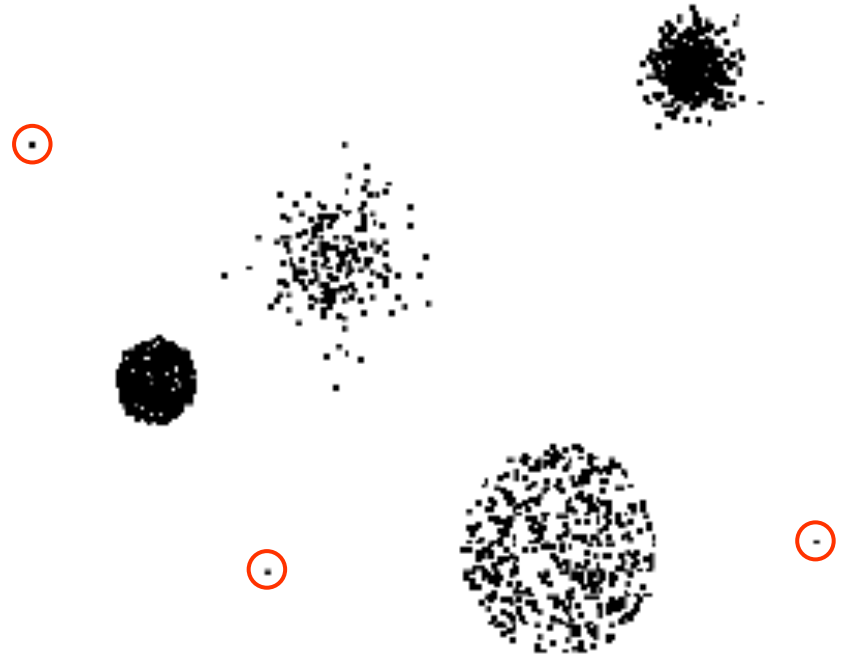

Missing Values

- Reasons for missing values
 - Information is not collected
(e.g., people decline to give their age and weight)
 - Attributes may not be applicable to all cases
(e.g., annual income is not applicable to children)
- Handling missing values
 - Eliminate data objects or variables
 - Estimate missing values
 - ◆ Example: time series of temperature
 - ◆ Example: census results
 - Ignore the missing value during analysis

Duplicate Data

- Data set may include data objects that are duplicates, or almost duplicates of one another
 - Major issue when merging data from heterogeneous sources
- Examples:
 - Same person with multiple email addresses
- Data cleaning
 - Process of dealing with duplicate data issues
- When should duplicate data not be removed?

Similarity and Dissimilarity Measures

- Similarity measure
 - Numerical measure of how alike two data objects are.
 - Is higher when objects are more alike.
 - Often falls in the range $[0,1]$
- Dissimilarity measure
 - Numerical measure of how different two data objects are
 - Lower when objects are more alike
 - Minimum dissimilarity is often 0
 - Upper limit varies
- **Proximity** refers to a similarity or dissimilarity

Similarity/Dissimilarity for Simple Attributes

The following table shows the similarity and dissimilarity between two objects, x and y , with respect to a single, simple attribute.

Attribute Type	Dissimilarity	Similarity
Nominal	$d = \begin{cases} 0 & \text{if } x = y \\ 1 & \text{if } x \neq y \end{cases}$	$s = \begin{cases} 1 & \text{if } x = y \\ 0 & \text{if } x \neq y \end{cases}$
Ordinal	$d = x - y / (n - 1)$ <p>(values mapped to integers 0 to $n-1$, where n is the number of values)</p>	$s = 1 - d$
Interval or Ratio	$d = x - y $	$s = -d, s = \frac{1}{1+d}, s = e^{-d},$ $s = 1 - \frac{d - \min_d}{\max_d - \min_d}$

Euclidean Distance

- Euclidean Distance

$$d(\mathbf{x}, \mathbf{y}) = \sqrt{\sum_{k=1}^n (x_k - y_k)^2}$$

where n is the number of dimensions (attributes) and x_k and y_k are, respectively, the k^{th} attributes (components) or data objects \mathbf{x} and \mathbf{y} .

- Standardization is necessary, if scales differ.

Euclidean Distance

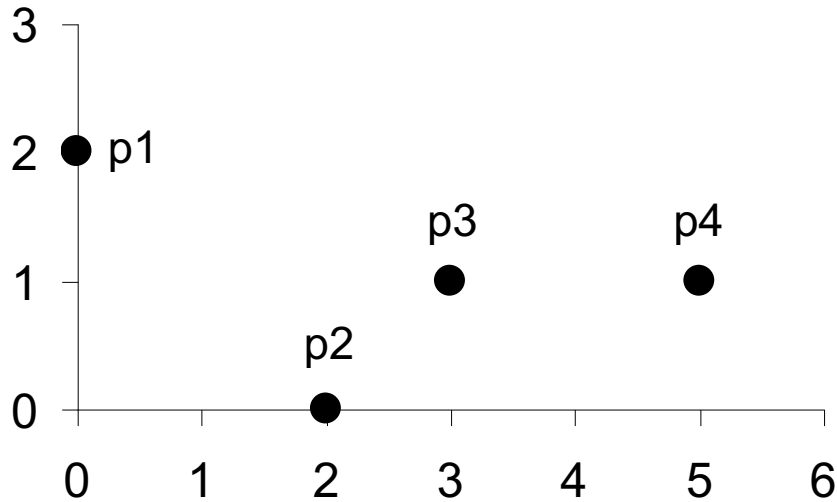

point	x	y
p1	0	2
p2	2	0
p3	3	1
p4	5	1

	p1	p2	p3	p4
p1	0	2.828	3.162	5.099
p2	2.828	0	1.414	3.162
p3	3.162	1.414	0	2
p4	5.099	3.162	2	0

Distance Matrix

Minkowski Distance

- Minkowski Distance is a generalization of Euclidean Distance

$$d(\mathbf{x}, \mathbf{y}) = \left(\sum_{k=1}^n |x_k - y_k|^r \right)^{1/r}$$

Where r is a parameter, n is the number of dimensions (attributes) and x_k and y_k are, respectively, the k^{th} attributes (components) or data objects \mathbf{x} and \mathbf{y} .

Minkowski Distance: Examples

- $r = 1$. City block (Manhattan, taxicab, L_1 norm) distance.
 - A common example of this for binary vectors is the Hamming distance, which is just the number of bits that are different between two binary vectors
- $r = 2$. Euclidean distance
- $r \rightarrow \infty$. “supremum” (L_{\max} norm, L_{∞} norm) distance.
 - This is the maximum difference between any component of the vectors
- Do not confuse r with n , i.e., all these distances are defined for all numbers of dimensions.

Minkowski Distance

point	x	y
p1	0	2
p2	2	0
p3	3	1
p4	5	1

L1	p1	p2	p3	p4
p1	0	4	4	6
p2	4	0	2	4
p3	4	2	0	2
p4	6	4	2	0

L2	p1	p2	p3	p4
p1	0	2.828	3.162	5.099
p2	2.828	0	1.414	3.162
p3	3.162	1.414	0	2
p4	5.099	3.162	2	0

L_{∞}	p1	p2	p3	p4
p1	0	2	3	5
p2	2	0	1	3
p3	3	1	0	2
p4	5	3	2	0

Distance Matrix

Mahalanobis Distance

$$\text{mahalanobis}(\mathbf{x}, \mathbf{y}) = ((\mathbf{x} - \mathbf{y})^T \Sigma^{-1} (\mathbf{x} - \mathbf{y}))^{-0.5}$$

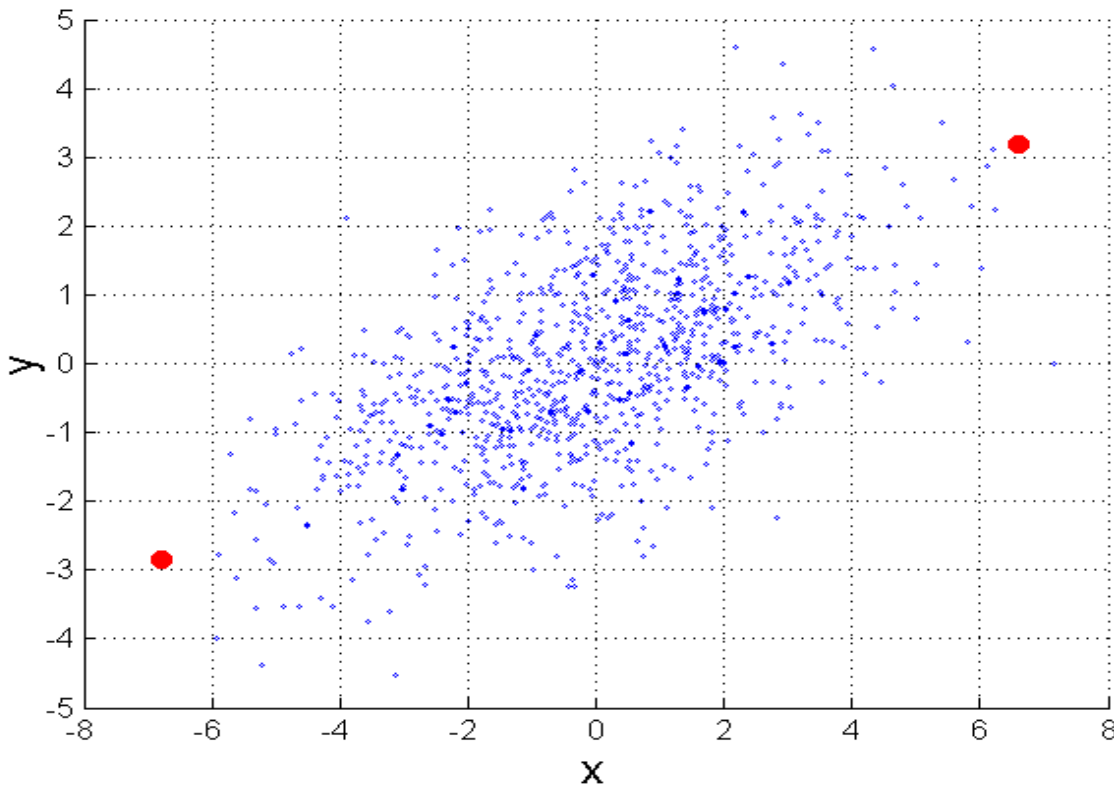

Σ is the covariance matrix

For red points, the Euclidean distance is 14.7, Mahalanobis distance is 6.

Mahalanobis Distance

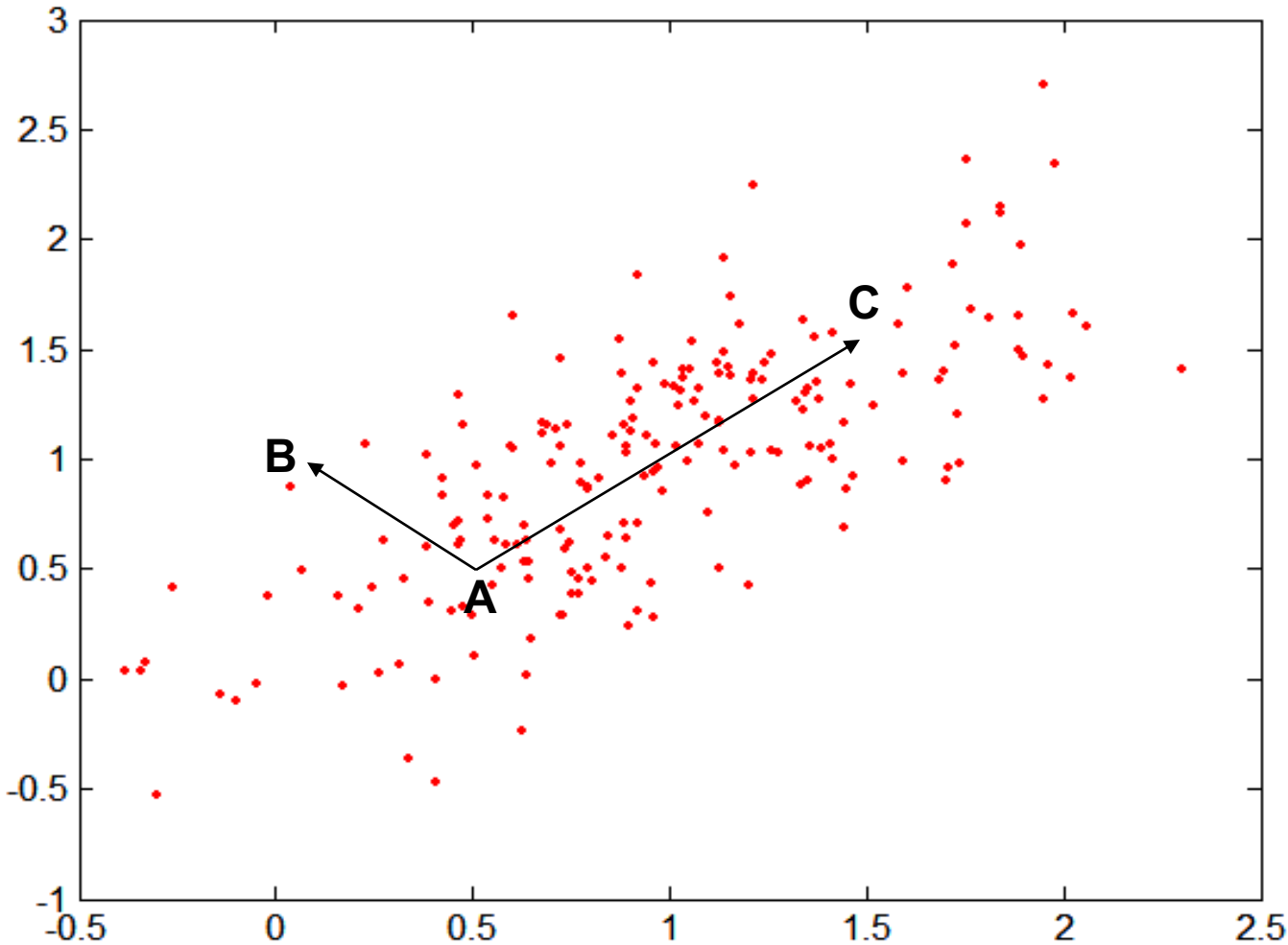

**Covariance
Matrix:**

$$\Sigma = \begin{bmatrix} 0.3 & 0.2 \\ 0.2 & 0.3 \end{bmatrix}$$

A: (0.5, 0.5)

B: (0, 1)

C: (1.5, 1.5)

Mahal(A,B) = 5

Mahal(A,C) = 4

Common Properties of a Distance

- Distances, such as the Euclidean distance, have some well known properties.
 1. $d(\mathbf{x}, \mathbf{y}) \geq 0$ for all x and y and $d(\mathbf{x}, \mathbf{y}) = 0$ if and only if $\mathbf{x} = \mathbf{y}$.
 2. $d(\mathbf{x}, \mathbf{y}) = d(\mathbf{y}, \mathbf{x})$ for all \mathbf{x} and \mathbf{y} . (Symmetry)
 3. $d(\mathbf{x}, \mathbf{z}) \leq d(\mathbf{x}, \mathbf{y}) + d(\mathbf{y}, \mathbf{z})$ for all points \mathbf{x} , \mathbf{y} , and \mathbf{z} . (Triangle Inequality)

where $d(\mathbf{x}, \mathbf{y})$ is the distance (dissimilarity) between points (data objects), \mathbf{x} and \mathbf{y} .

- A distance that satisfies these properties is a **metric**

Common Properties of a Similarity

- Similarities, also have some well known properties.
 1. $s(\mathbf{x}, \mathbf{y}) = 1$ (or maximum similarity) only if $\mathbf{x} = \mathbf{y}$.
(does not always hold, e.g., cosine)
 2. $s(\mathbf{x}, \mathbf{y}) = s(\mathbf{y}, \mathbf{x})$ for all \mathbf{x} and \mathbf{y} . (Symmetry)

where $s(\mathbf{x}, \mathbf{y})$ is the similarity between points (data objects), \mathbf{x} and \mathbf{y} .

Similarity Between Binary Vectors

- Common situation is that objects, x and y , have only binary attributes

- Compute similarities using the following quantities

f_{01} = the number of attributes where x was 0 and y was 1

f_{10} = the number of attributes where x was 1 and y was 0

f_{00} = the number of attributes where x was 0 and y was 0

f_{11} = the number of attributes where x was 1 and y was 1

- Simple Matching and Jaccard Coefficients

SMC = number of matches / number of attributes

$$= (f_{11} + f_{00}) / (f_{01} + f_{10} + f_{11} + f_{00})$$

J = number of 11 matches / number of non-zero attributes

$$= (f_{11}) / (f_{01} + f_{10} + f_{11})$$

SMC versus Jaccard: Example

$$\mathbf{x} = 1\ 0\ 0\ 0\ 0\ 0\ 0\ 0\ 0\ 0\ 0$$

$$\mathbf{y} = 0\ 0\ 0\ 0\ 0\ 0\ 1\ 0\ 0\ 1$$

$$f_{01} = 2 \quad (\text{the number of attributes where } \mathbf{x} \text{ was } 0 \text{ and } \mathbf{y} \text{ was } 1)$$

$$f_{10} = 1 \quad (\text{the number of attributes where } \mathbf{x} \text{ was } 1 \text{ and } \mathbf{y} \text{ was } 0)$$

$$f_{00} = 7 \quad (\text{the number of attributes where } \mathbf{x} \text{ was } 0 \text{ and } \mathbf{y} \text{ was } 0)$$

$$f_{11} = 0 \quad (\text{the number of attributes where } \mathbf{x} \text{ was } 1 \text{ and } \mathbf{y} \text{ was } 1)$$

$$\begin{aligned} \text{SMC} &= (f_{11} + f_{00}) / (f_{01} + f_{10} + f_{11} + f_{00}) \\ &= (0+7) / (2+1+0+7) = 0.7 \end{aligned}$$

$$J = (f_{11}) / (f_{01} + f_{10} + f_{11}) = 0 / (2 + 1 + 0) = 0$$

Cosine Similarity

- If \mathbf{d}_1 and \mathbf{d}_2 are two document vectors, then

$$\cos(\mathbf{d}_1, \mathbf{d}_2) = \langle \mathbf{d}_1, \mathbf{d}_2 \rangle / \|\mathbf{d}_1\| \|\mathbf{d}_2\| ,$$

where $\langle \mathbf{d}_1, \mathbf{d}_2 \rangle$ indicates inner product or vector dot product of vectors, \mathbf{d}_1 and \mathbf{d}_2 , and $\|\mathbf{d}\|$ is the length of vector \mathbf{d} .

- Example:

$$\mathbf{d}_1 = 3 \ 2 \ 0 \ 5 \ 0 \ 0 \ 0 \ 2 \ 0 \ 0$$

$$\mathbf{d}_2 = 1 \ 0 \ 0 \ 0 \ 0 \ 0 \ 0 \ 1 \ 0 \ 2$$

$$\langle \mathbf{d}_1, \mathbf{d}_2 \rangle = 3*1 + 2*0 + 0*0 + 5*0 + 0*0 + 0*0 + 0*0 + 2*1 + 0*0 + 0*2 = 5$$

$$\|\mathbf{d}_1\| = (3*3 + 2*2 + 0*0 + 5*5 + 0*0 + 0*0 + 0*0 + 2*2 + 0*0 + 0*0)^{0.5} = (42)^{0.5} = 6.481$$

$$\|\mathbf{d}_2\| = (1*1 + 0*0 + 0*0 + 0*0 + 0*0 + 0*0 + 0*0 + 1*1 + 0*0 + 2*2)^{0.5} = (6)^{0.5} = 2.449$$

$$\cos(\mathbf{d}_1, \mathbf{d}_2) = 0.3150$$

Correlation measures the linear relationship between objects

$$\text{corr}(\mathbf{x}, \mathbf{y}) = \frac{\text{covariance}(\mathbf{x}, \mathbf{y})}{\text{standard_deviation}(\mathbf{x}) * \text{standard_deviation}(\mathbf{y})} = \frac{s_{xy}}{s_x s_y}, \quad (2.11)$$

where we are using the following standard statistical notation and definitions

$$\text{covariance}(\mathbf{x}, \mathbf{y}) = s_{xy} = \frac{1}{n-1} \sum_{k=1}^n (x_k - \bar{x})(y_k - \bar{y}) \quad (2.12)$$

$$\text{standard_deviation}(\mathbf{x}) = s_x = \sqrt{\frac{1}{n-1} \sum_{k=1}^n (x_k - \bar{x})^2}$$

$$\text{standard_deviation}(\mathbf{y}) = s_y = \sqrt{\frac{1}{n-1} \sum_{k=1}^n (y_k - \bar{y})^2}$$

$$\bar{x} = \frac{1}{n} \sum_{k=1}^n x_k \text{ is the mean of } \mathbf{x}$$

$$\bar{y} = \frac{1}{n} \sum_{k=1}^n y_k \text{ is the mean of } \mathbf{y}$$

Visually Evaluating Correlation

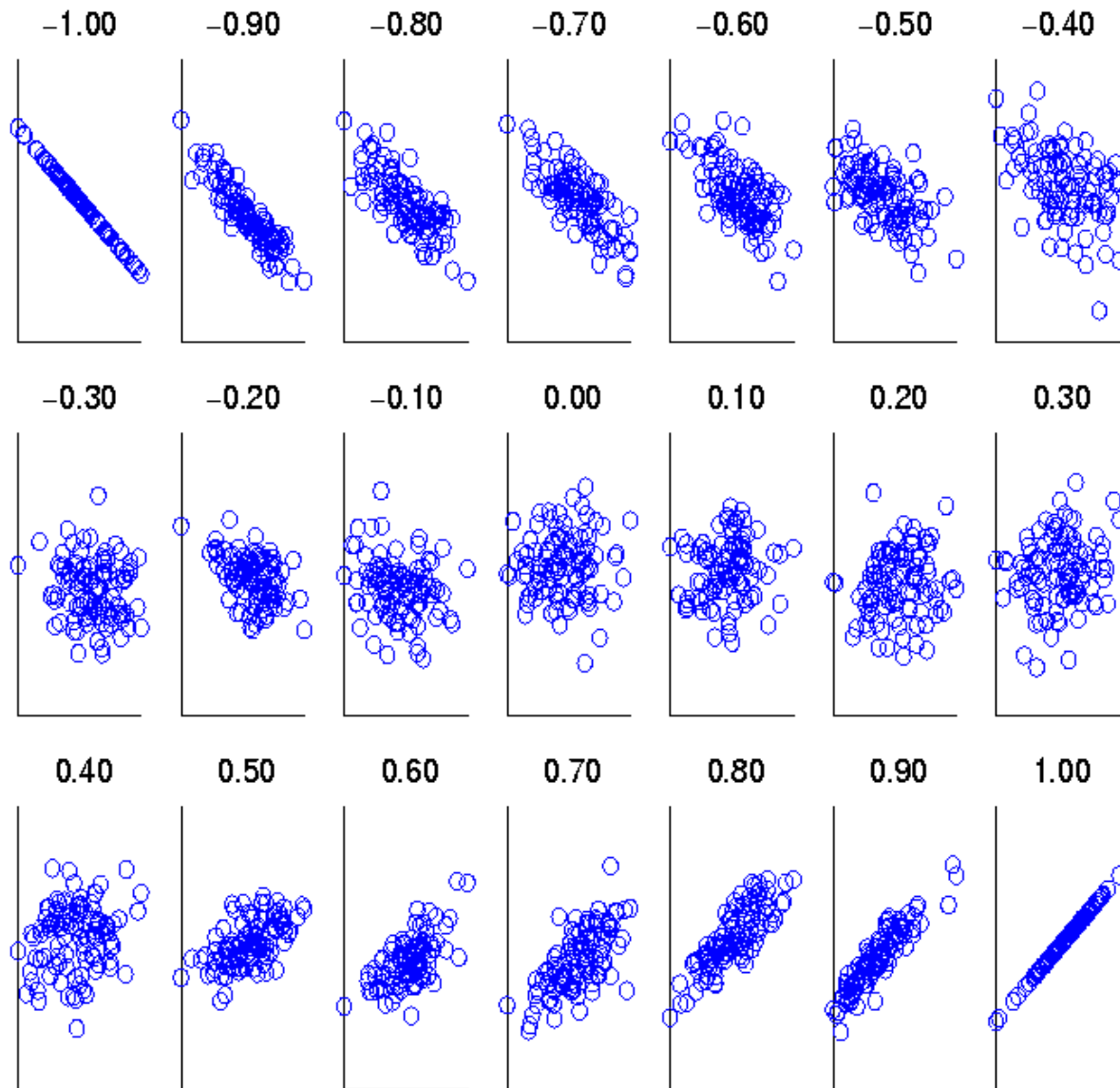

Scatter plots showing the similarity from -1 to 1.

Drawback of Correlation

- $\mathbf{x} = (-3, -2, -1, 0, 1, 2, 3)$

- $\mathbf{y} = (9, 4, 1, 0, 1, 4, 9)$

$$y_i = x_i^2$$

- $\text{mean}(\mathbf{x}) = 0, \text{mean}(\mathbf{y}) = 4$

- $\text{std}(\mathbf{x}) = 2.16, \text{std}(\mathbf{y}) = 3.74$

- $\text{corr} = (-3)(5)+(-2)(0)+(-1)(-3)+(0)(-4)+(1)(-3)+(2)(0)+3(5) / (6 * 2.16 * 3.74)$
 $= 0$

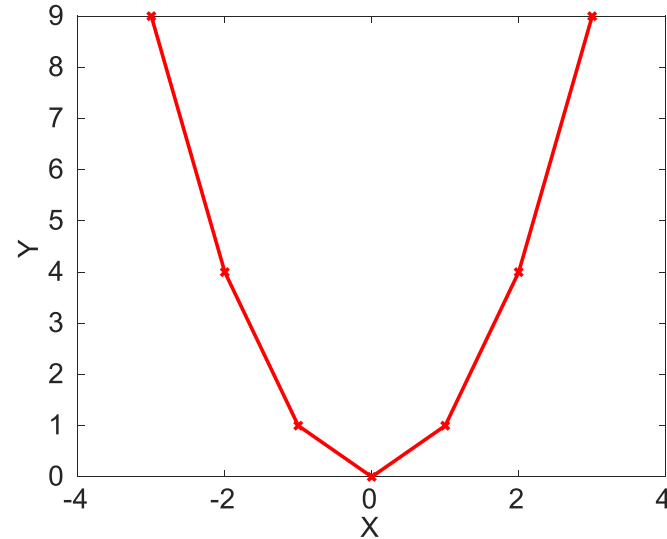

Correlation vs Cosine vs Euclidean Distance

- Compare the three proximity measures according to their behavior under variable transformation
 - scaling: multiplication by a value
 - translation: adding a constant

Property	Cosine	Correlation	Euclidean Distance
Invariant to scaling (multiplication)	Yes	Yes	No
Invariant to translation (addition)	No	Yes	No

- Consider the example
 - $\mathbf{x} = (1, 2, 4, 3, 0, 0, 0)$, $\mathbf{y} = (1, 2, 3, 4, 0, 0, 0)$
 - $\mathbf{y}_s = \mathbf{y} * 2$ (scaled version of \mathbf{y}), $\mathbf{y}_t = \mathbf{y} + 5$ (translated version)

Measure	(\mathbf{x}, \mathbf{y})	$(\mathbf{x}, \mathbf{y}_s)$	$(\mathbf{x}, \mathbf{y}_t)$
Cosine	0.9667	0.9667	0.7940
Correlation	0.9429	0.9429	0.9429
Euclidean Distance	1.4142	5.8310	14.2127

Correlation vs cosine vs Euclidean distance

- Choice of the right proximity measure depends on the domain
- What is the correct choice of proximity measure for the following situations?
 - Comparing documents using the frequencies of words
 - ◆ Documents are considered similar if the word frequencies are similar
 - Comparing the temperature in Celsius of two locations
 - ◆ Two locations are considered similar if the temperatures are similar in magnitude
 - Comparing two time series of temperature measured in Celsius
 - ◆ Two time series are considered similar if their “shape” is similar, i.e., they vary in the same way over time, achieving minimums and maximums at similar times, etc.

Comparison of Proximity Measures

- Domain of application
 - Similarity measures tend to be specific to the type of attribute and data
 - Record data, images, graphs, sequences, 3D-protein structure, etc. tend to have different measures
- However, one can talk about various properties that you would like a proximity measure to have
 - Symmetry is a common one
 - Tolerance to noise and outliers is another
 - Ability to find more types of patterns?
 - Many others possible
- The measure must be applicable to the data and produce results that agree with domain knowledge

Information Based Measures

- Information theory is a well-developed and fundamental discipline with broad applications
- Some similarity measures are based on information theory
 - Mutual information in various versions
 - Maximal Information Coefficient (MIC) and related measures
 - General and can handle non-linear relationships
 - Can be complicated and time intensive to compute

Information and Probability

- Information relates to possible outcomes of an event
 - transmission of a message, flip of a coin, or measurement of a piece of data



- The more certain an outcome, the less information that it contains and vice-versa
 - For example, if a coin has two heads, then an outcome of heads provides no information
 - More quantitatively, the information is related the probability of an outcome
 - ◆ The smaller the probability of an outcome, the more information it provides and vice-versa
 - Entropy is the commonly used measure

Entropy

- For
 - a variable (event), X ,
 - with n possible values (outcomes), $x_1, x_2 \dots, x_n$
 - each outcome having probability, $p_1, p_2 \dots, p_n$
 - the entropy of X , $H(X)$, is given by

$$H(X) = - \sum_{i=1}^n p_i \log_2 p_i$$

- Entropy is between 0 and $\log_2 n$ and is measured in bits
 - Thus, entropy is a measure of how many bits it takes to represent an observation of X on average

Entropy Examples

- For a coin with probability p of heads and probability $q = 1 - p$ of tails

$$H = -p \log_2 p - q \log_2 q$$

- For $p = 0.5, q = 0.5$ (fair coin) $H = 1$
 - For $p = 1$ or $q = 1, H = 0$
-
- What is the entropy of a fair four-sided die?

Entropy for Sample Data: Example

Hair Color	Count	p	$-p\log_2 p$
Black	75	0.75	0.3113
Brown	15	0.15	0.4105
Blond	5	0.05	0.2161
Red	0	0.00	0
Other	5	0.05	0.2161
Total	100	1.0	1.1540

Maximum entropy is $\log_2 5 = 2.3219$

Entropy for Sample Data

- Suppose we have
 - a number of observations (m) of some attribute, X , e.g., the hair color of students in the class,
 - where there are n different possible values
 - And the number of observation in the i^{th} category is m_i
 - Then, for this sample

$$H(X) = - \sum_{i=1}^n \frac{m_i}{m} \log_2 \frac{m_i}{m}$$

- For continuous data, the calculation is harder

Mutual Information

- Information one variable provides about another

Formally, $I(X, Y) = H(X) + H(Y) - H(X, Y)$, where

$H(X, Y)$ is the joint entropy of X and Y ,

$$H(X, Y) = - \sum_i \sum_j p_{ij} \log_2 p_{ij}$$

Where p_{ij} is the probability that the i^{th} value of X and the j^{th} value of Y occur together

- For discrete variables, this is easy to compute
- Maximum mutual information for discrete variables is $\log_2(\min(n_X, n_Y))$, where n_X (n_Y) is the number of values of X (Y)

Mutual Information Example

Student Status	Count	p	$-p\log_2 p$
Undergrad	45	0.45	0.5184
Grad	55	0.55	0.4744
Total	100	1.00	0.9928

Grade	Count	p	$-p\log_2 p$
A	35	0.35	0.5301
B	50	0.50	0.5000
C	15	0.15	0.4105
Total	100	1.00	1.4406

Student Status	Grade	Count	p	$-p\log_2 p$
Undergrad	A	5	0.05	0.2161
Undergrad	B	30	0.30	0.5211
Undergrad	C	10	0.10	0.3322
Grad	A	30	0.30	0.5211
Grad	B	20	0.20	0.4644
Grad	C	5	0.05	0.2161
Total		100	1.00	2.2710

Mutual information of Student Status and Grade = $0.9928 + 1.4406 - 2.2710 = 0.1624$

Maximal Information Coefficient

- Reshef, David N., Yakir A. Reshef, Hilary K. Finucane, Sharon R. Grossman, Gilean McVean, Peter J. Turnbaugh, Eric S. Lander, Michael Mitzenmacher, and Pardis C. Sabeti. "Detecting novel associations in large data sets." *science* 334, no. 6062 (2011): 1518-1524.
- Applies mutual information to two continuous variables
- Consider the possible binnings of the variables into discrete categories
 - $n_X \times n_Y \leq N^{0.6}$ where
 - ◆ n_X is the number of values of X
 - ◆ n_Y is the number of values of Y
 - ◆ N is the number of samples (observations, data objects)
- Compute the mutual information
 - Normalized by $\log_2(\min(n_X, n_Y))$
- Take the highest value

General Approach for Combining Similarities

- Sometimes attributes are of many different types, but an overall similarity is needed.

1: For the k^{th} attribute, compute a similarity, $s_k(\mathbf{x}, \mathbf{y})$, in the range $[0, 1]$.

2: Define an indicator variable, δ_k , for the k^{th} attribute as follows:

$\delta_k = 0$ if the k^{th} attribute is an asymmetric attribute and both objects have a value of 0, or if one of the objects has a missing value for the k^{th} attribute

$\delta_k = 1$ otherwise

3. Compute $\text{similarity}(\mathbf{x}, \mathbf{y}) = \frac{\sum_{k=1}^n \delta_k s_k(\mathbf{x}, \mathbf{y})}{\sum_{k=1}^n \delta_k}$

Using Weights to Combine Similarities

- May not want to treat all attributes the same.
 - Use non-negative weights ω_k

- $similarity(\mathbf{x}, \mathbf{y}) = \frac{\sum_{k=1}^n \omega_k \delta_k s_k(\mathbf{x}, \mathbf{y})}{\sum_{k=1}^n \omega_k \delta_k}$

- Can also define a weighted form of distance

$$d(\mathbf{x}, \mathbf{y}) = \left(\sum_{k=1}^n \omega_k |x_k - y_k|^r \right)^{1/r}$$

Data Preprocessing

- Aggregation
- Sampling
- Discretization and Binarization
- Attribute Transformation
- Dimensionality Reduction
- Feature subset selection
- Feature creation

Aggregation

- Combining two or more attributes (or objects) into a single attribute (or object)
- Purpose
 - Data reduction - reduce the number of attributes or objects
 - Change of scale
 - ◆ Cities aggregated into regions, states, countries, etc.
 - ◆ Days aggregated into weeks, months, or years
 - More “stable” data - aggregated data tends to have less variability

Table 2.4. Data set containing information about customer purchases.

Transaction ID	Item	Store Location	Date	Price	...
⋮	⋮	⋮	⋮	⋮	⋮
101123	Watch	Chicago	09/06/04	\$25.99	...
101123	Battery	Chicago	09/06/04	\$5.99	...
101124	Shoes	Minneapolis	09/06/04	\$75.00	...
⋮	⋮	⋮	⋮	⋮	⋮

Example: Precipitation in Australia

- This example is based on precipitation in Australia from the period 1982 to 1993.
The next slide shows
 - A histogram for the standard deviation of average monthly precipitation for 3,030 0.5° by 0.5° grid cells in Australia, and
 - A histogram for the standard deviation of the average yearly precipitation for the same locations.
- The average yearly precipitation has less variability than the average monthly precipitation.
- All precipitation measurements (and their standard deviations) are in centimeters.

Example: Precipitation in Australia ...

Variation of Precipitation in Australia

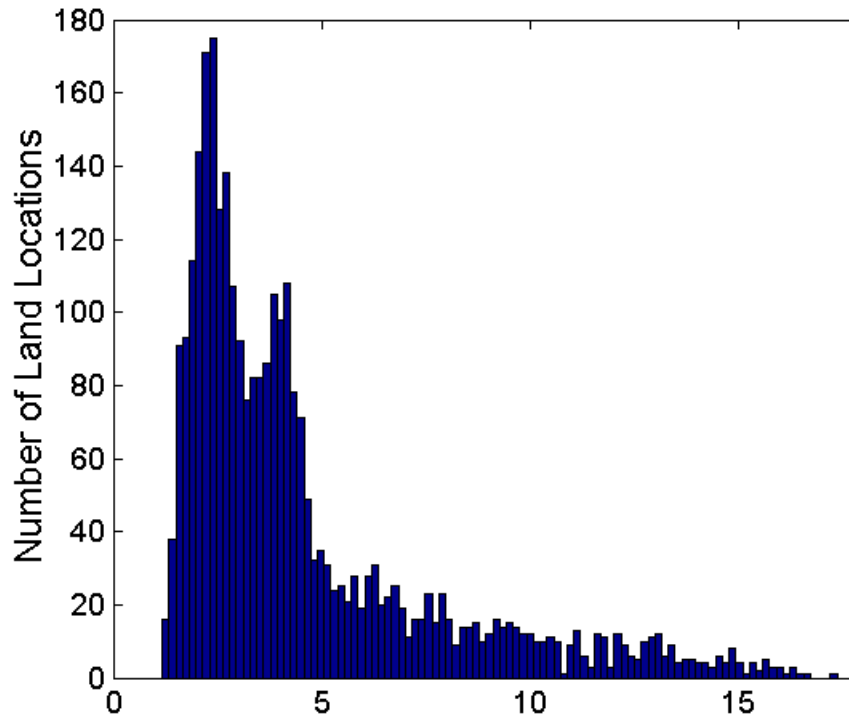

Standard Deviation of Average Monthly Precipitation

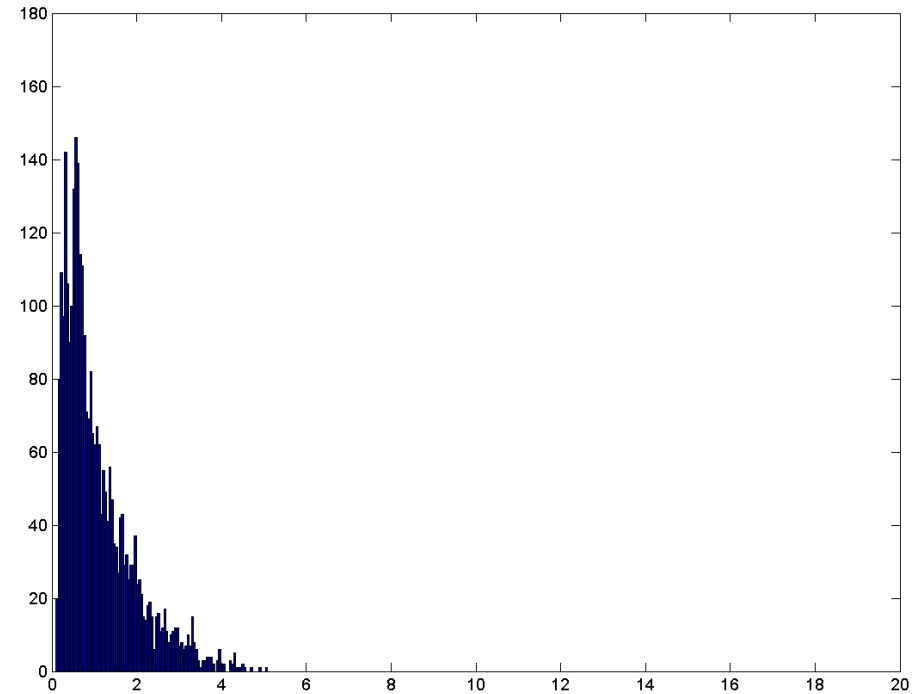

Standard Deviation of Average Yearly Precipitation

Sampling

- Sampling is the main technique employed for data reduction.
 - It is often used for both the preliminary investigation of the data and the final data analysis.
- Statisticians often sample because **obtaining** the entire set of data of interest is too expensive or time consuming.
- Sampling is typically used in data mining because **processing** the entire set of data of interest is too expensive or time consuming.

Sampling ...

- The key principle for effective sampling is the following:
 - Using a sample will work almost as well as using the entire data set, if the sample is **representative**
 - A sample is **representative** if it has approximately the same properties (of interest) as the original set of data

Sample Size

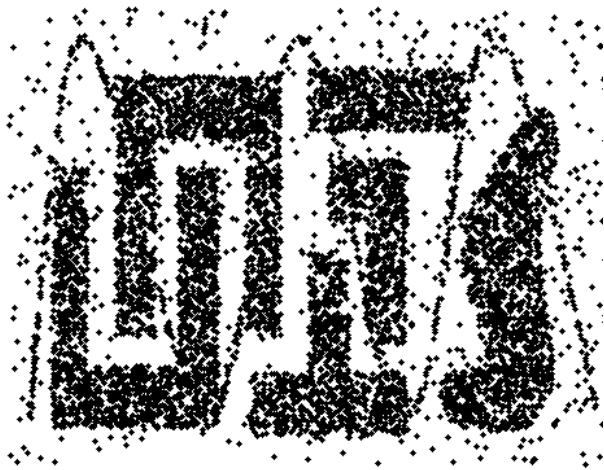

8000 points

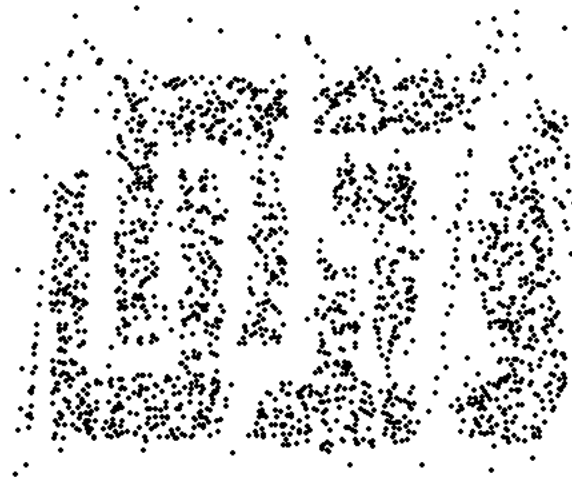

2000 Points

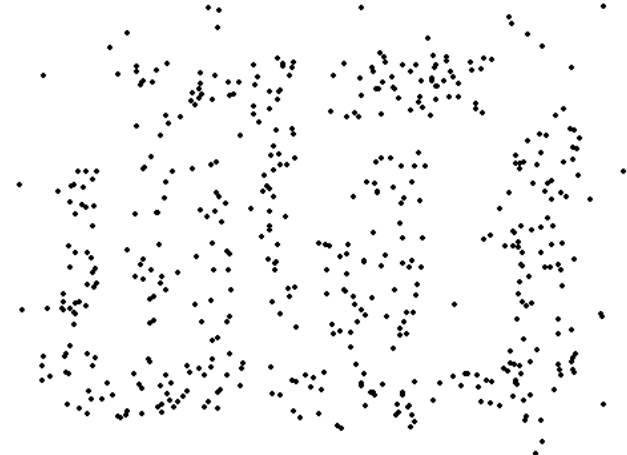

500 Points

Types of Sampling

- Simple Random Sampling

- There is an equal probability of selecting any particular item
- Sampling without replacement
 - ◆ As each item is selected, it is removed from the population
- Sampling with replacement
 - ◆ Objects are not removed from the population as they are selected for the sample.
 - ◆ In sampling with replacement, the same object can be picked up more than once

- Stratified sampling

- Split the data into several partitions; then draw random samples from each partition

Sample Size

- What sample size is necessary to get at least one object from each of 10 equal-sized groups.

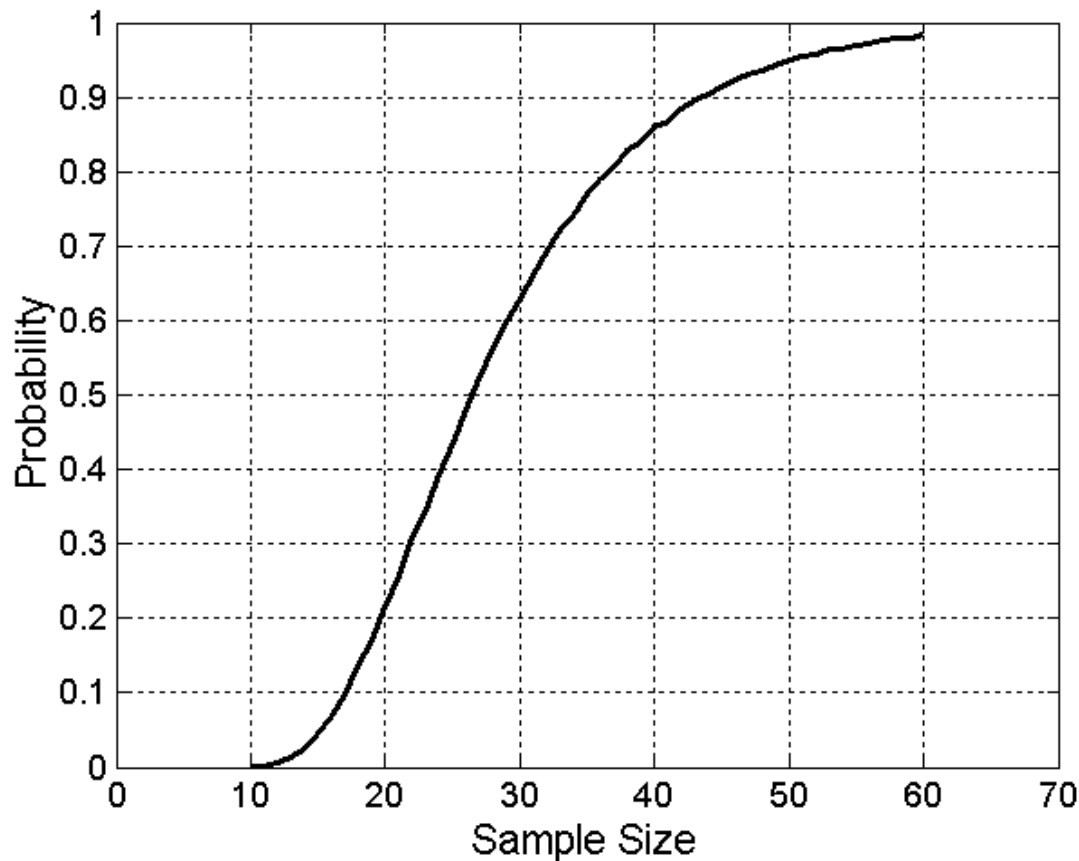

Discretization

- **Discretization** is the process of converting a continuous attribute into an ordinal attribute
 - A potentially infinite number of values are mapped into a small number of categories
 - Discretization is used in both unsupervised and supervised settings

Unsupervised Discretization

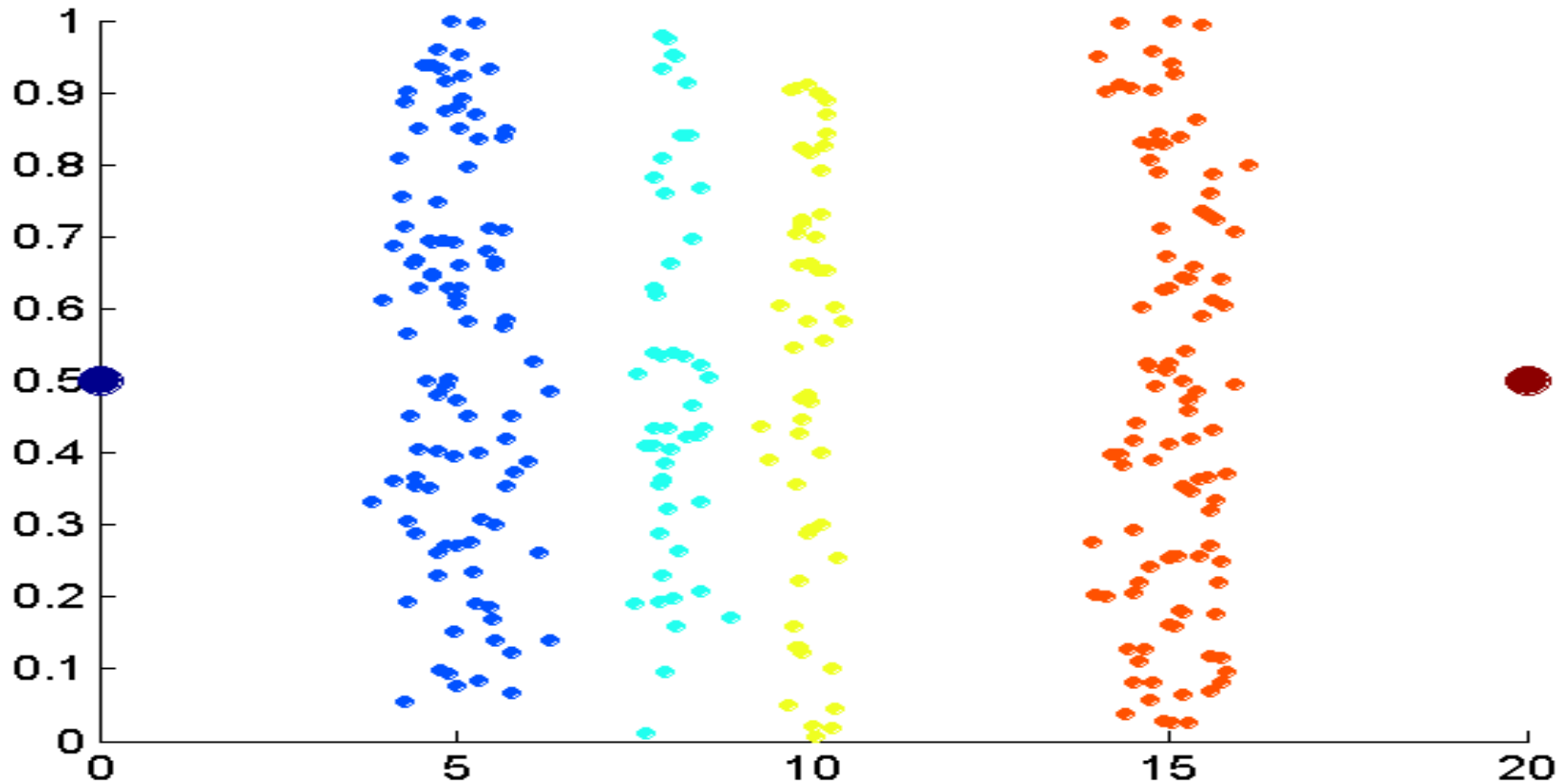

Data consists of four groups of points and two outliers. Data is one-dimensional, but a random y component is added to reduce overlap.

Unsupervised Discretization

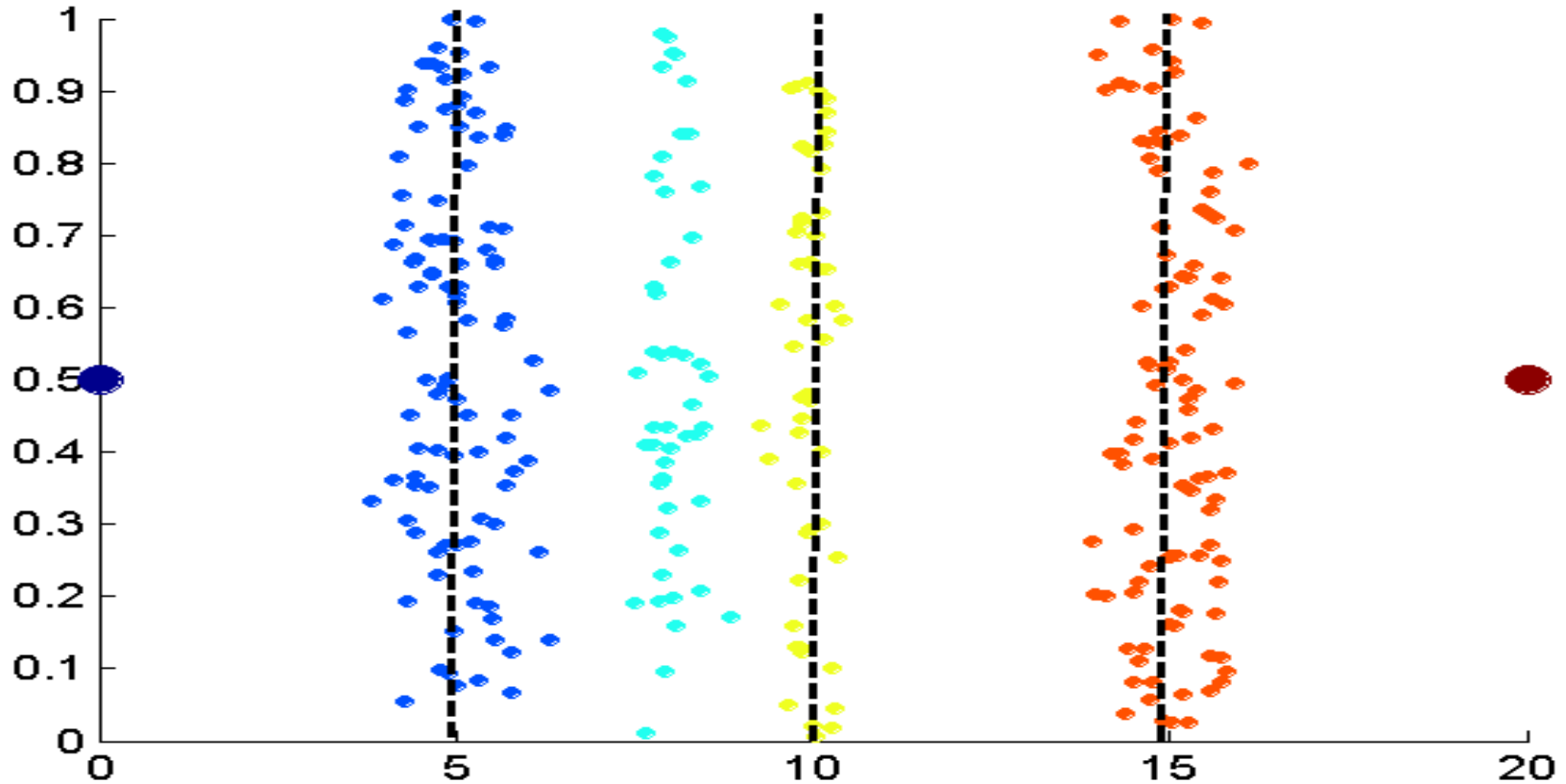

Equal interval width approach used to obtain 4 values.

Unsupervised Discretization

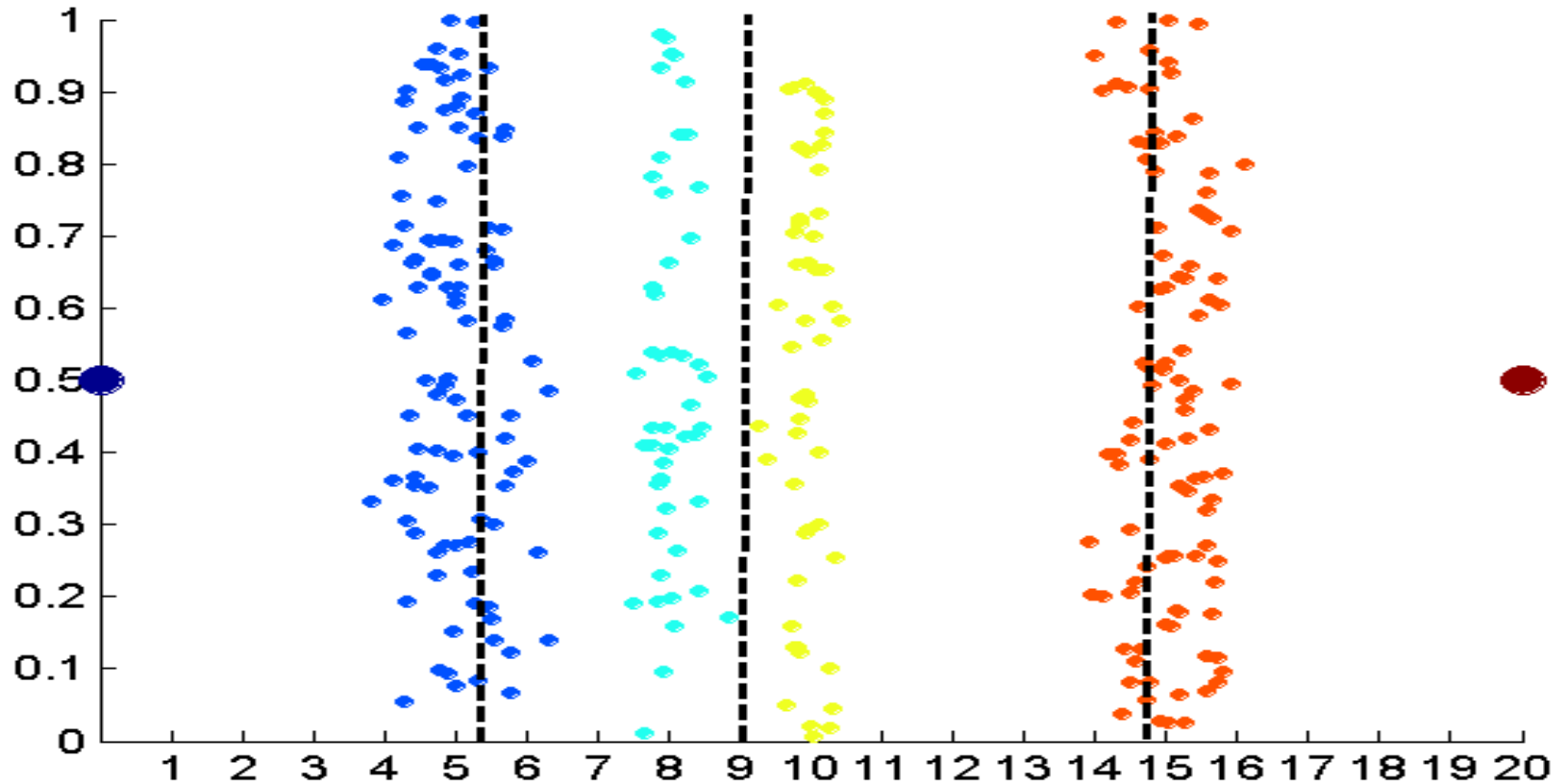

Equal frequency approach used to obtain 4 values.

Unsupervised Discretization

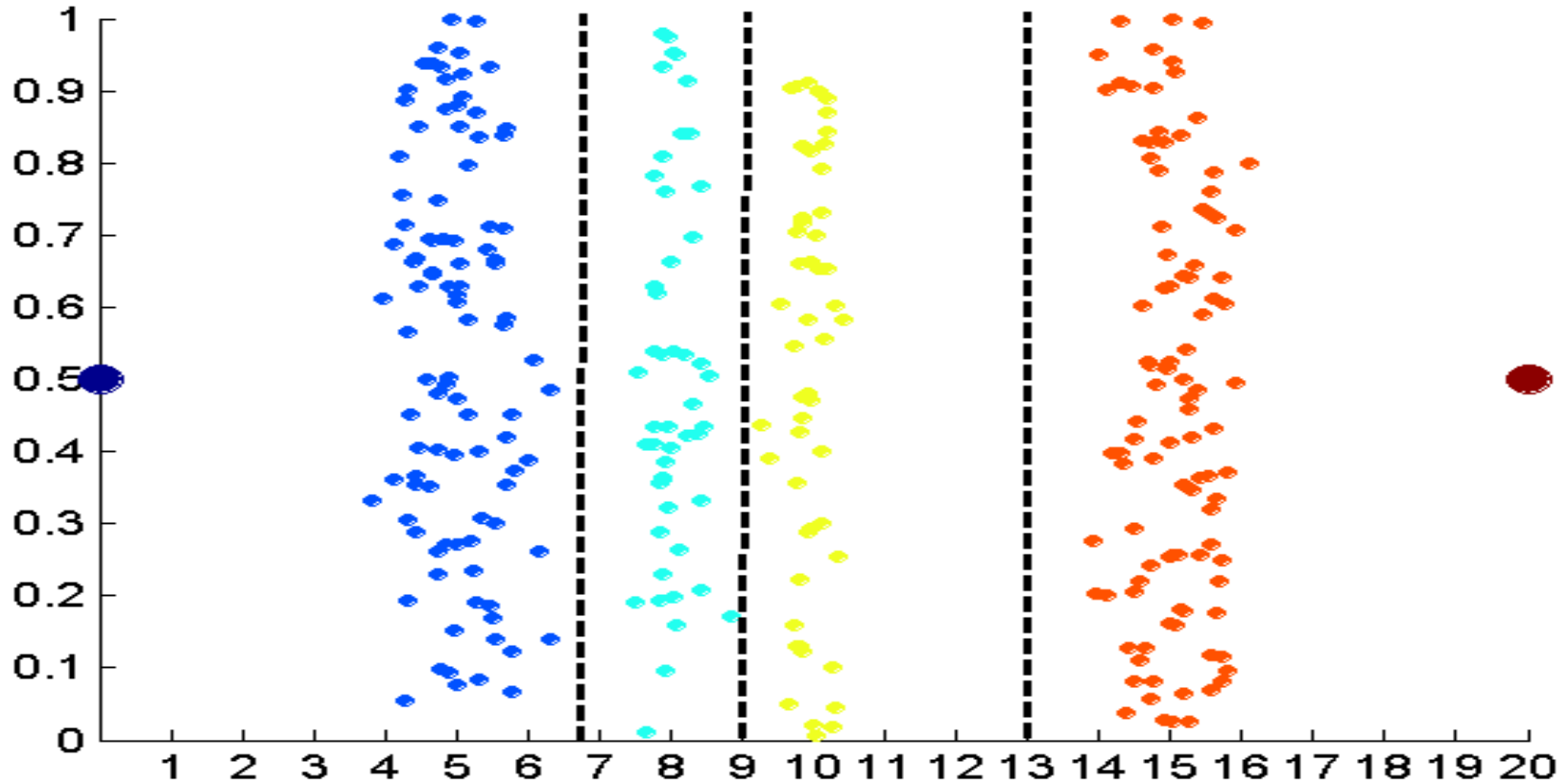

K-means approach to obtain 4 values.

Discretization in Supervised Settings

- Many classification algorithms work best if both the independent and dependent variables have only a few values
- We give an illustration of the usefulness of discretization using the following example.

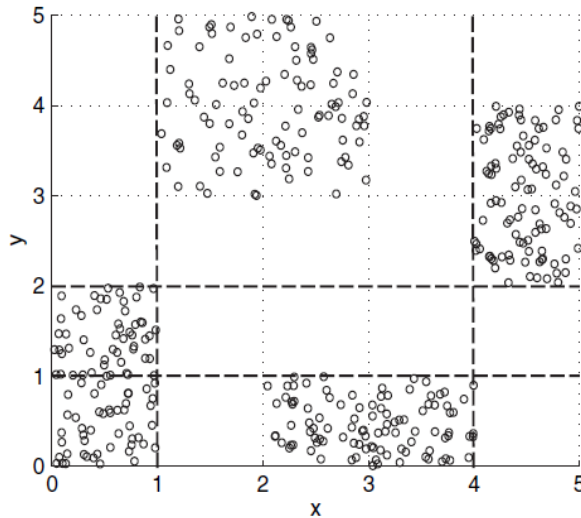

(a) Three intervals

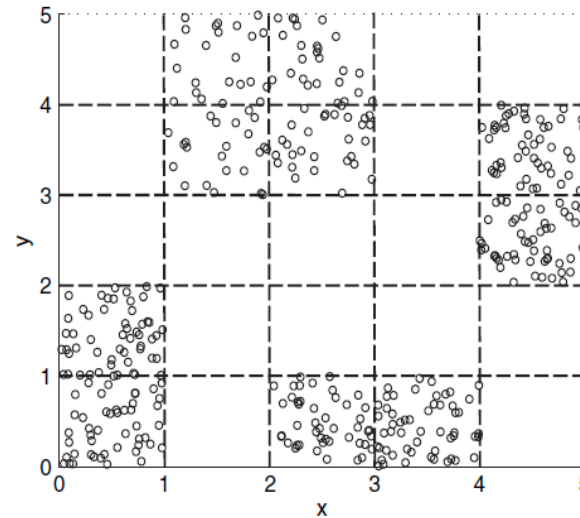

(b) Five intervals

Figure 2.14. Discretizing x and y attributes for four groups (classes) of points.

Binarization

- Binarization maps a continuous or categorical attribute into one or more binary variables

Table 2.6. Conversion of a categorical attribute to five asymmetric binary attributes.

Categorical Value	Integer Value	x_1	x_2	x_3	x_4	x_5
<i>awful</i>	0	1	0	0	0	0
<i>poor</i>	1	0	1	0	0	0
<i>OK</i>	2	0	0	1	0	0
<i>good</i>	3	0	0	0	1	0
<i>great</i>	4	0	0	0	0	1

Attribute Transformation

- An **attribute transform** is a function that maps the entire set of values of a given attribute to a new set of replacement values such that each old value can be identified with one of the new values
 - Simple functions: x^k , $\log(x)$, e^x , $|x|$
 - **Normalization**
 - ◆ Refers to various techniques to adjust to differences among attributes in terms of frequency of occurrence, mean, variance, range
 - ◆ Take out unwanted, common signal, e.g., seasonality
 - In statistics, **standardization** refers to subtracting off the means and dividing by the standard deviation

Example: Sample Time Series of Plant Growth

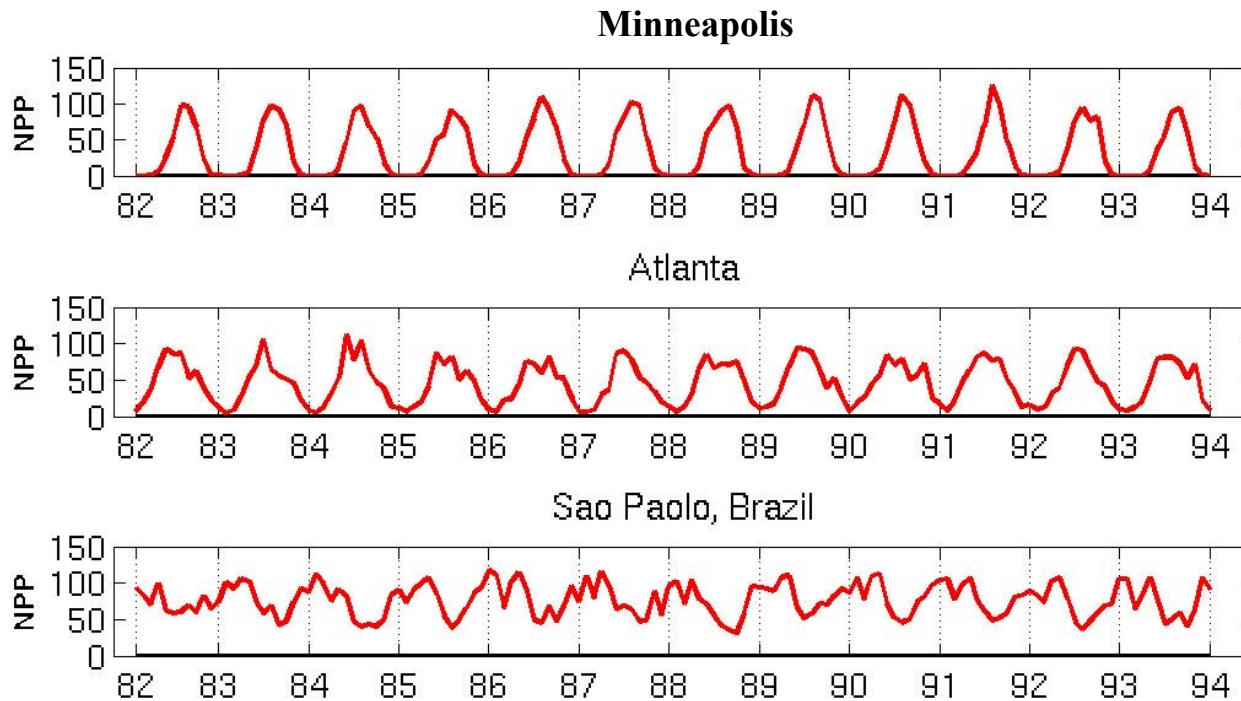

Net Primary Production (NPP) is a measure of plant growth used by ecosystem scientists.

Correlations between time series

	Minneapolis	Atlanta	Sao Paulo
Minneapolis	1.0000	0.7591	-0.7581
Atlanta	0.7591	1.0000	-0.5739
Sao Paulo	-0.7581	-0.5739	1.0000

Seasonality Accounts for Much Correlation

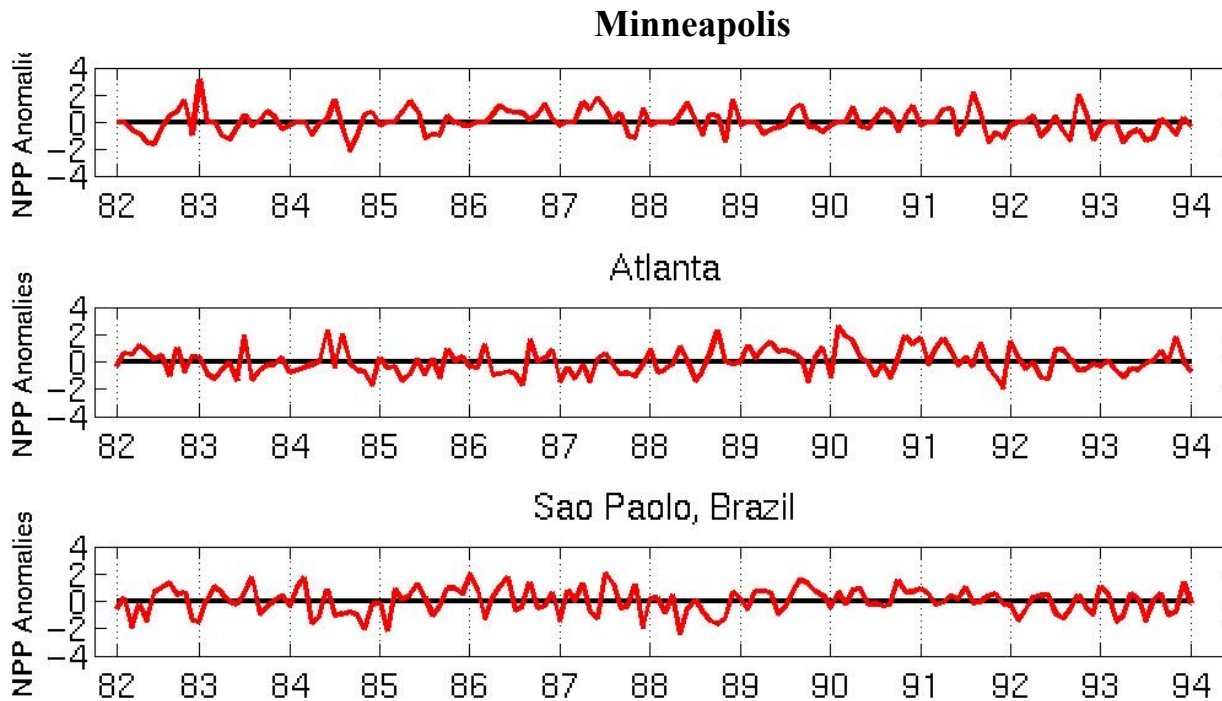

Normalized using
monthly Z Score:

Subtract off monthly
mean and divide by
monthly standard
deviation

Correlations between time series

	Minneapolis	Atlanta	Sao Paulo
Minneapolis	1.0000	0.0492	0.0906
Atlanta	0.0492	1.0000	-0.0154
Sao Paulo	0.0906	-0.0154	1.0000

Curse of Dimensionality

- When dimensionality increases, data becomes increasingly sparse in the space that it occupies
- Definitions of density and distance between points, which are critical for clustering and outlier detection, become less meaningful

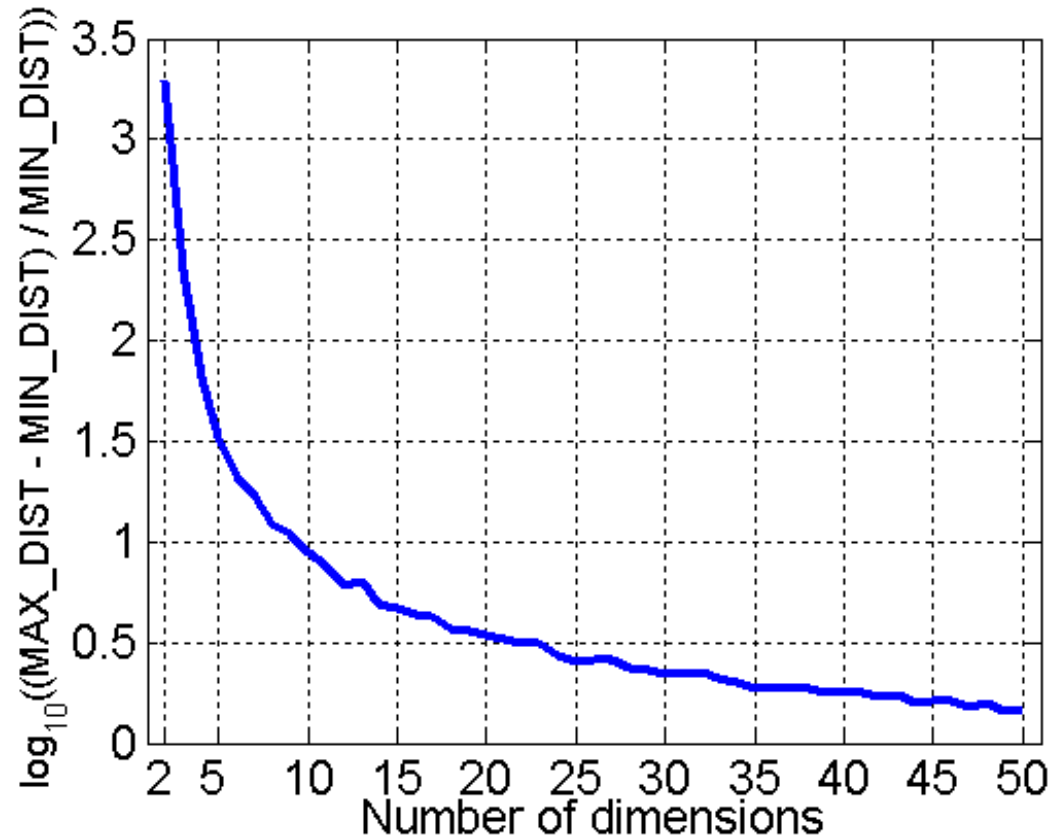

- Randomly generate 500 points
- Compute difference between max and min distance between any pair of points

Dimensionality Reduction

- Purpose:

- Avoid curse of dimensionality
- Reduce amount of time and memory required by data mining algorithms
- Allow data to be more easily visualized
- May help to eliminate irrelevant features or reduce noise

- Techniques

- Principal Components Analysis (PCA)
- Singular Value Decomposition
- Others: supervised and non-linear techniques

Dimensionality Reduction: PCA

- Goal is to find a projection that captures the largest amount of variation in data

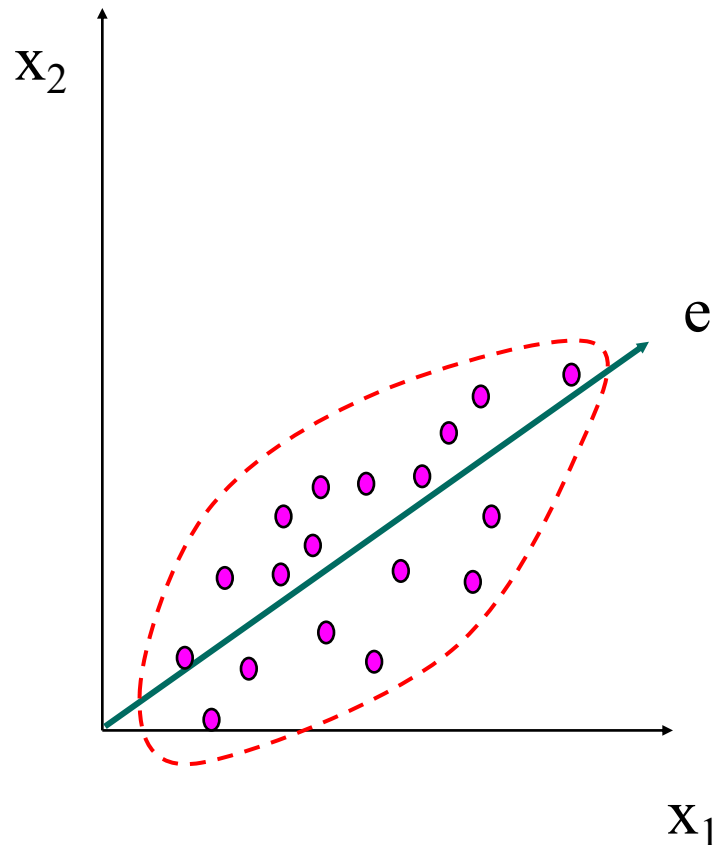

Dimensionality Reduction: PCA

256



Feature Subset Selection

- Another way to reduce dimensionality of data
- Redundant features
 - Duplicate much or all of the information contained in one or more other attributes
 - Example: purchase price of a product and the amount of sales tax paid
- Irrelevant features
 - Contain no information that is useful for the data mining task at hand
 - Example: students' ID is often irrelevant to the task of predicting students' GPA
- Many techniques developed, especially for classification

Feature Creation

- Create new attributes that can capture the important information in a data set much more efficiently than the original attributes
- Three general methodologies:
 - Feature extraction
 - ◆ Example: extracting edges from images
 - Feature construction
 - ◆ Example: dividing mass by volume to get density
 - Mapping data to new space
 - ◆ Example: Fourier and wavelet analysis

Mapping Data to a New Space

● Fourier and wavelet transform

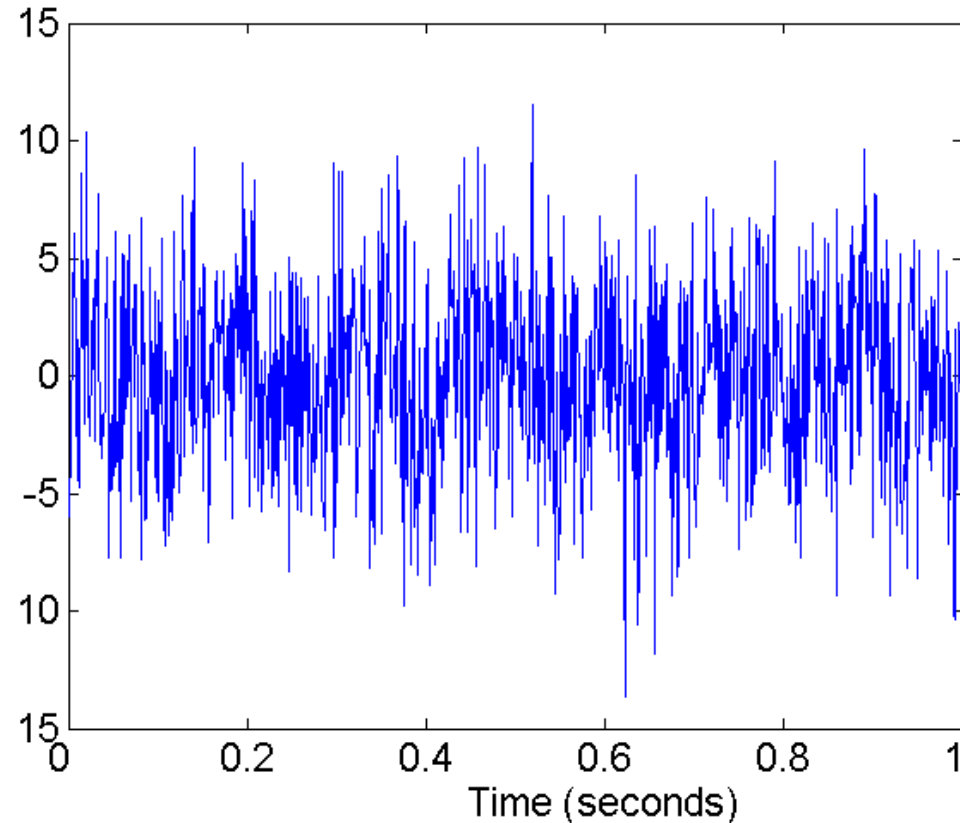

Two Sine Waves + Noise

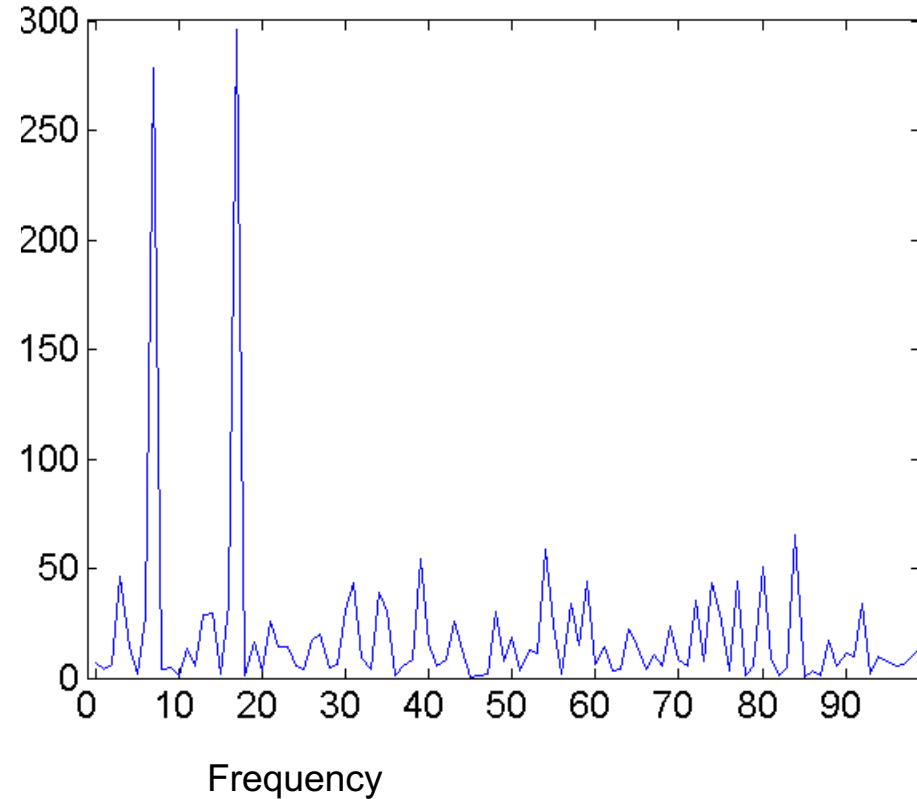

Frequency